

ASCON spa

ISO 9001
Certified

ASCON spa
20021 Bollate
(Milano) Italy
via Falzarego, 9/11
Tel. +39 02 333 371
Fax +39 02 350 4243
<http://www.ascon.it>
e-mail info@ascon.it

Heat / Cool
temperature controller
1/8 DIN - 48 x 96



X1 line

User Manual • M.I.U.X1 -2/01.01 • Cod. J30-478-1AX1 IE



**Heat / Cool
temperature controller
1/8 DIN - 48 x 96**

X1 line

CE

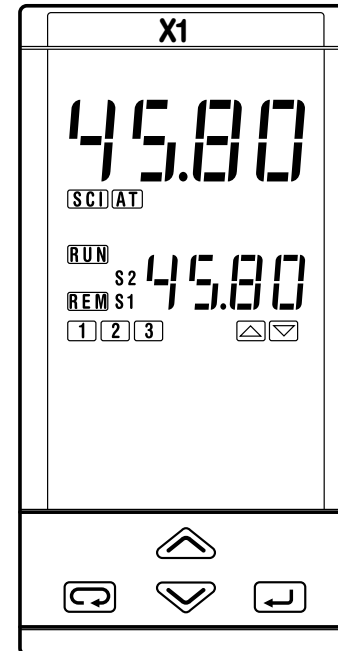



NOTES

ON ELECTRIC SAFETY AND ELECTROMAGNETIC COMPATIBILITY

Please, read carefully these instructions before proceeding with the installation of the controller.

Class II instrument, rear panel mounting.

This controller has been designed with compliance to:

Regulations on electrical apparatus (appliance, systems and installations) according to the European Community directive 73/23 CEE amended by the European Community directive 93/68 CEE and the Regulations on the essential protection requirements in electrical apparatus EN 61010-1 (IEC 1010 - 1) : 90 +A1:92 + A2:95.

Regulations on Electromagnetic Compatibility according to the European Community directive n°89/336/CEE, amended by the European Community directive n° 92/31/CEE and the following regulations:

Regulations on RF emissions

EN50081 - 1 residential environments

EN50081 - 2 for industrial environments

Regulation on RF immunity

EN500082-2 for industrial equipment and system

It is important to understand that it's responsibility of the installer to ensure the compliance of the regulations on safety requirements and EMC.

The repair of this controller has no user serviceable parts and requires special equipment and specialised engineers. Therefore, a repair can be hardly carried on directly by the user. For this purpose, the manufacturer provides technical assistance and the repair service for its Customers.

Please, contact your nearest Agent for further information.

All the information and warnings about safety and electromagnetic compatibility are marked with the  sign, at the side of the note.

TABLE OF CONTENTS

1	INSTALLATION	Page 4
2	ELECTRICAL CONNECTIONS	Page 8
3	PRODUCT CODING	Page 16
4	OPERATIONS	Page 21
5	DISPLAYS	Page 47
6	COMMANDS	Page 48
7	TECHNICAL SPECIFICATIONS	Page 52

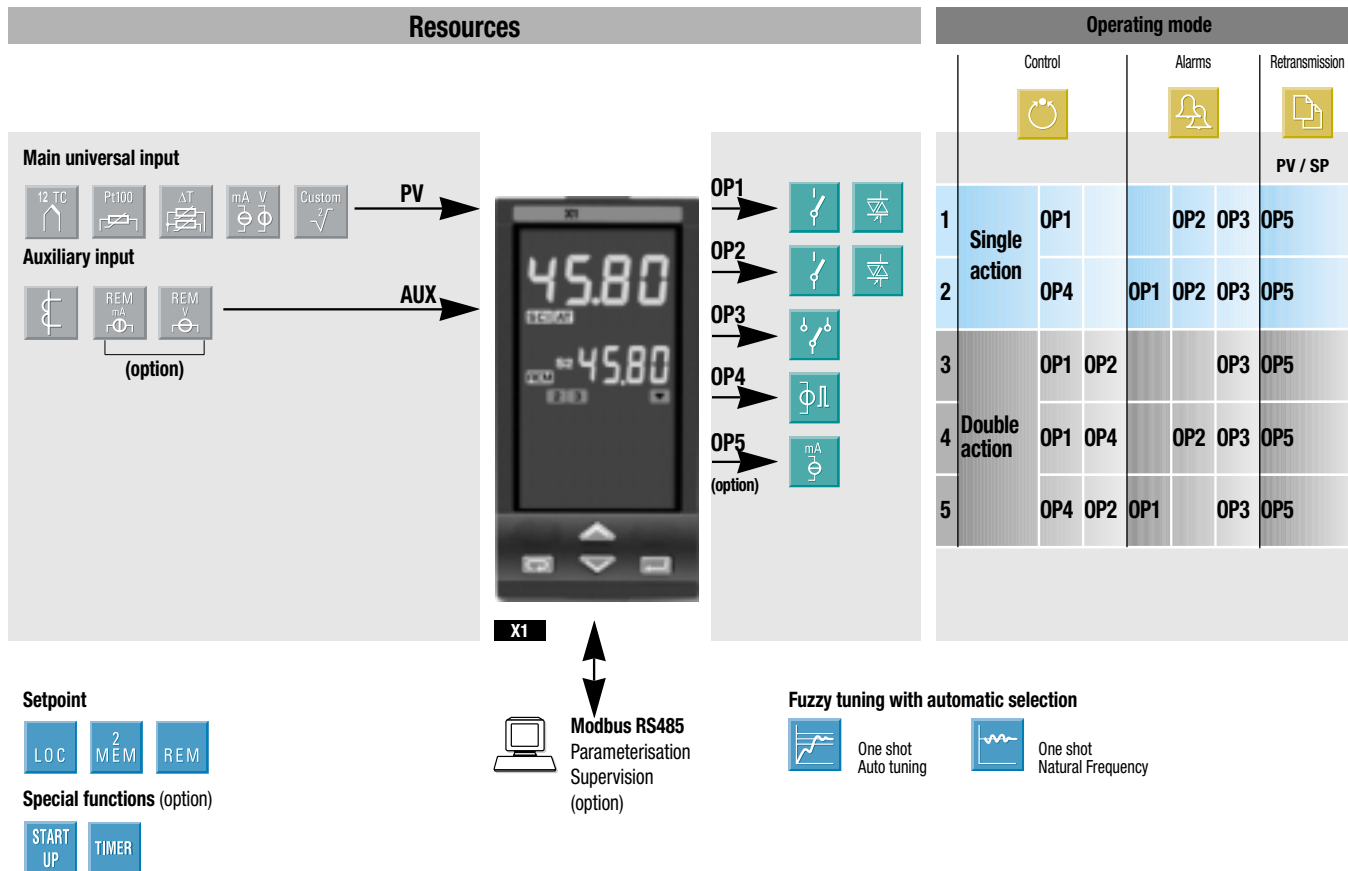

1 INSTALLATION

Installation must only be carried out by qualified personnel.

Before proceeding with the installation of this controller, follow the instructions illustrated in this manual and, particularly the installation precautions marked with the  symbol, related to the European Community directive on electrical protection and electromagnetic compatibility.



To prevent hands or metal touching parts that may be electrically live, **the controllers must be installed in an enclosure and/or in a cubicle.**

1.1 GENERAL DESCRIPTION

IP 20 Termination Unit
EN61010 - 1 (IEC1010 - 1)

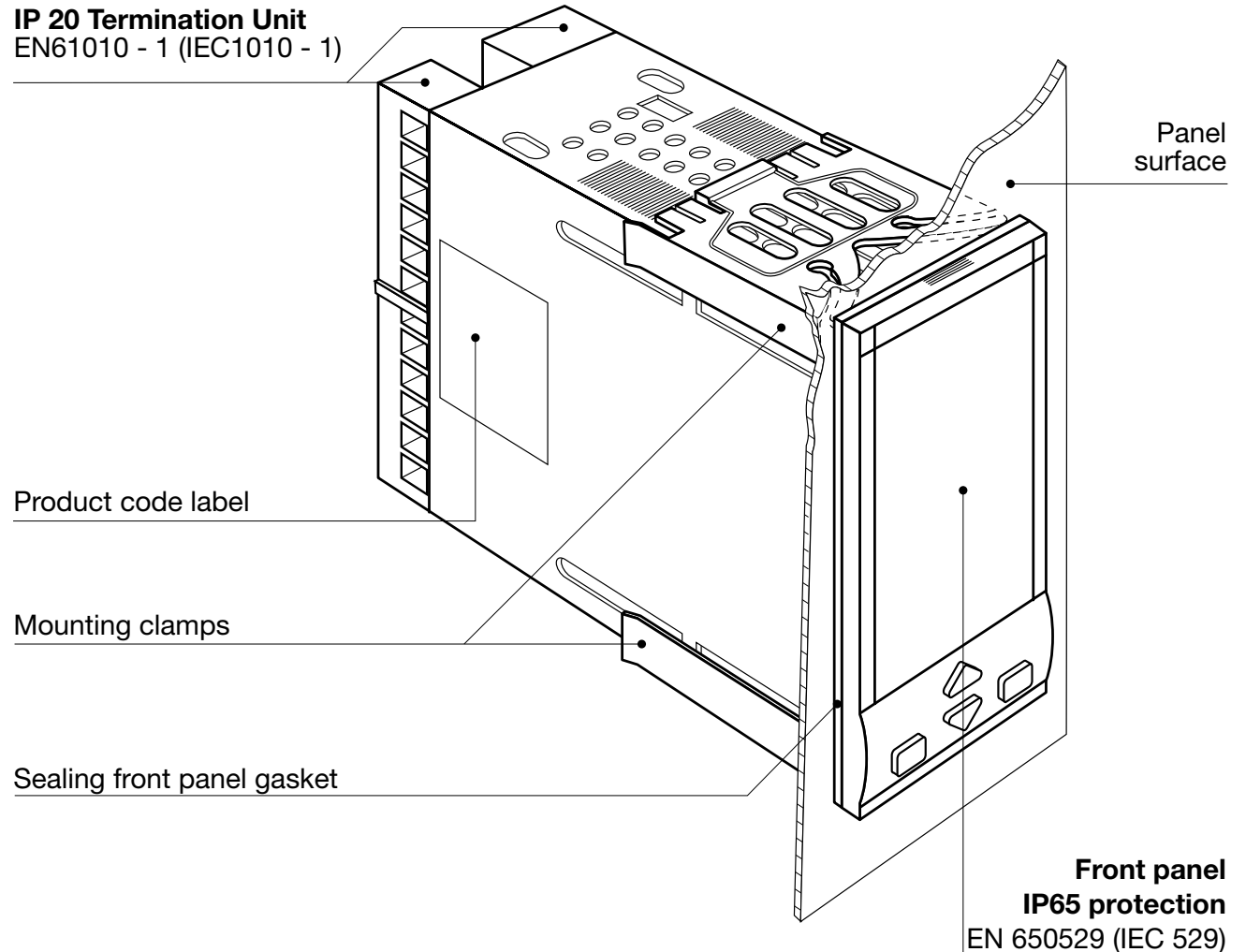

1.2 PANEL CUT-OUT

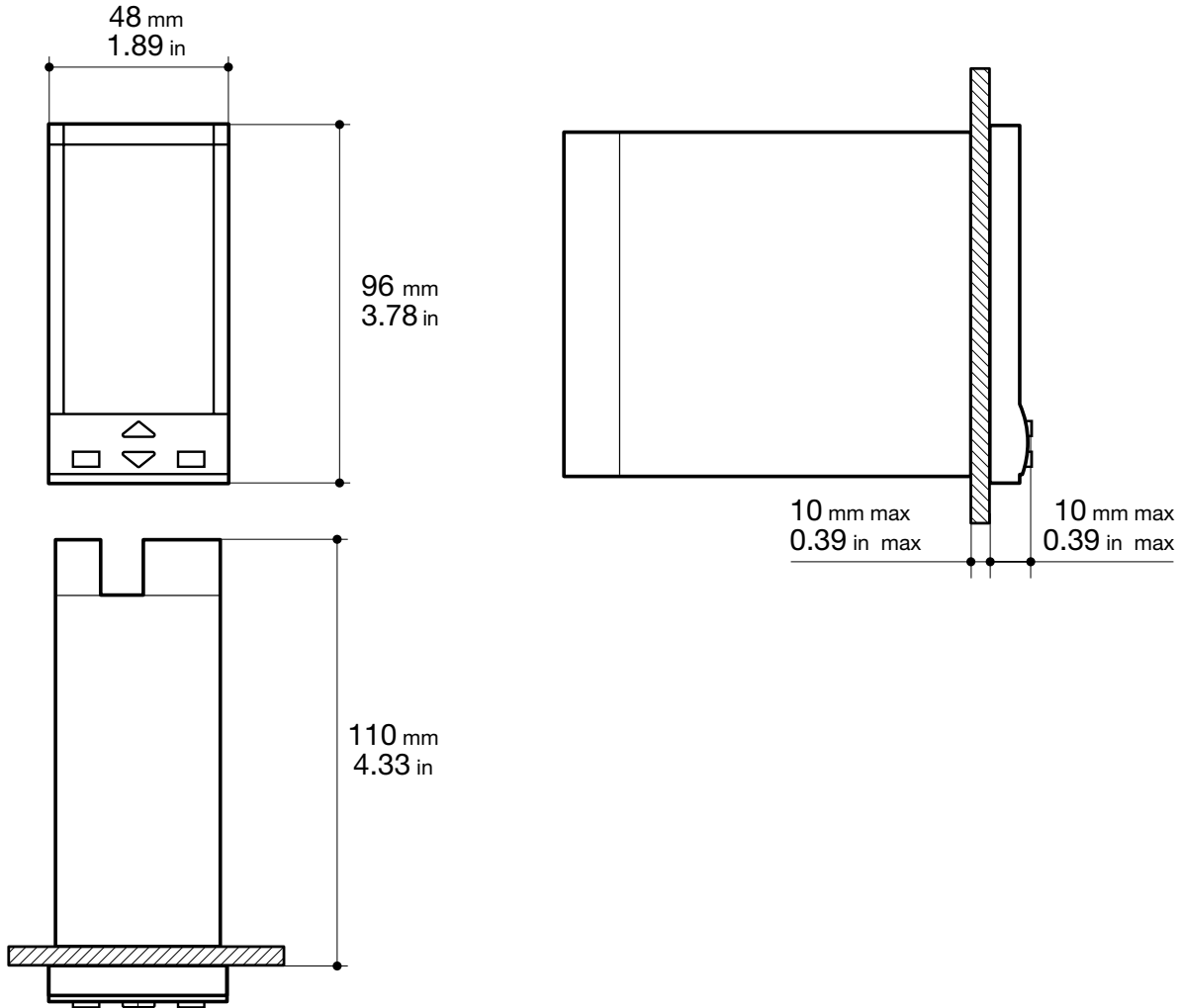

1.3 PANEL CUT-OUT

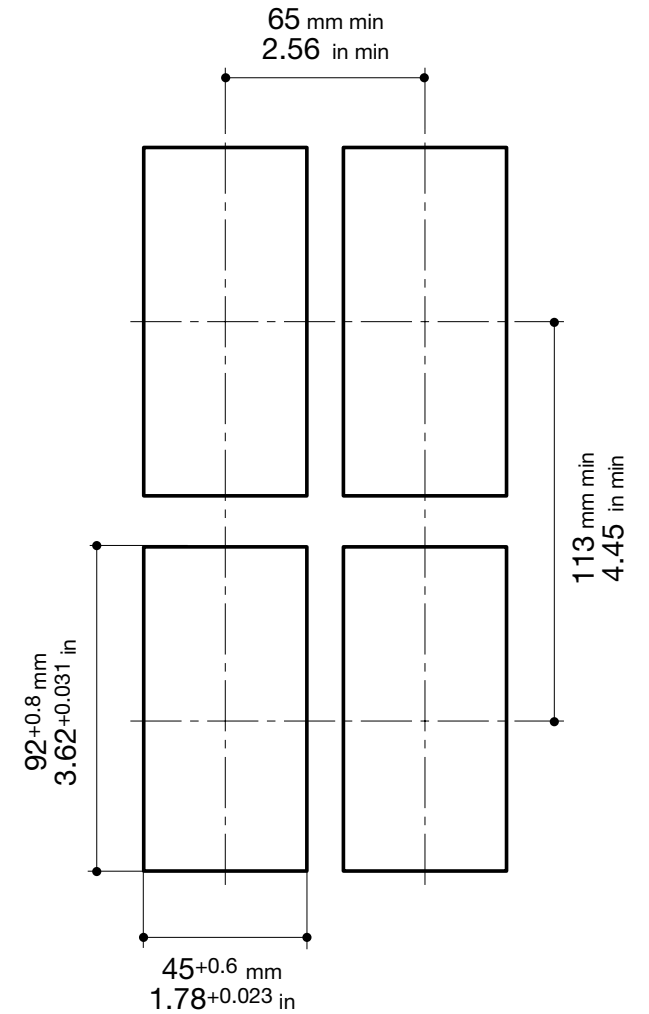

1.4 ENVIRONMENTAL RATINGS



Operating conditions



Altitude up to 2000 m



Temperature 0...50°C

%Rh

Relative humidity 5...95 % non-condensing

Special conditions

Suggestions



Altitude > 2000 m

Use 24V~ supply version



Temperature >50°C

Use forced air ventilation

%Rh

Humidity > 95 %

Warm up



Conducting atmosphere

Use filter

Forbidden Conditions 



Corrosive atmosphere



Explosive atmosphere

1.5 PANEL MOUNTING

1.5.1 INSERT THE INSTRUMENT

- 1 Prepare panel cut-out
- 2 Check front panel gasket position
- 3 Insert the instrument through the cut-out

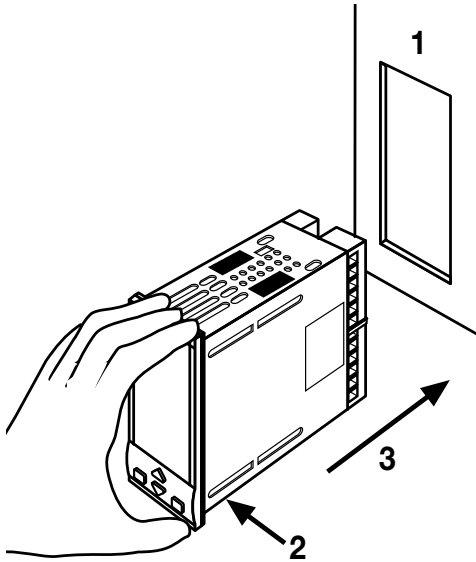

1.5.2 INSTALLATION SECURING

- 1 Fit the mounting clamps
- 2 Push the mounting clamps towards the panel surface to secure the instrument

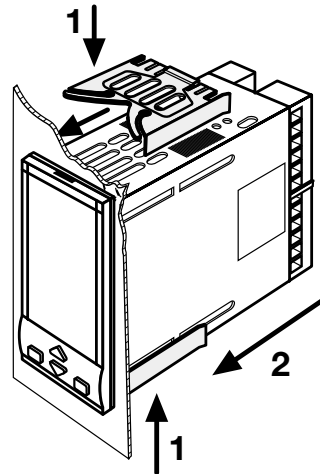

1.5.3 CLAMPS REMOVING

- 1 Insert the screwdriver in the clips of the clamps
- 2 Rotate the screwdriver

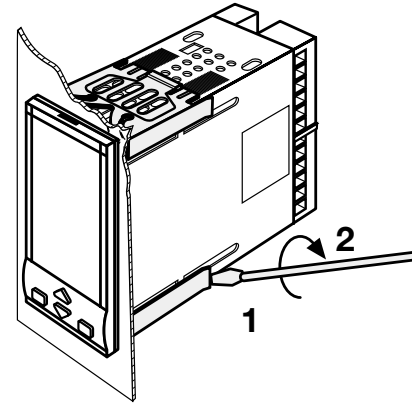

1.5.4 INSTRUMENT UNPLUGGING



- 1 Push and
- 2 pull to remove the instrument

Electrostatic discharges can damage the instrument

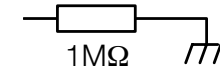

Before removing the instrument the operator must discharge himself to ground

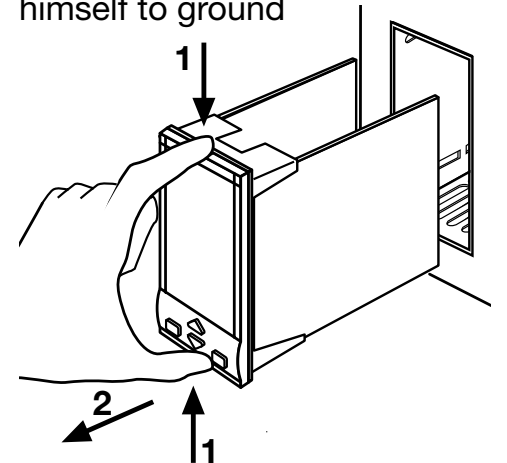

ELECTRICAL CONNECTIONS

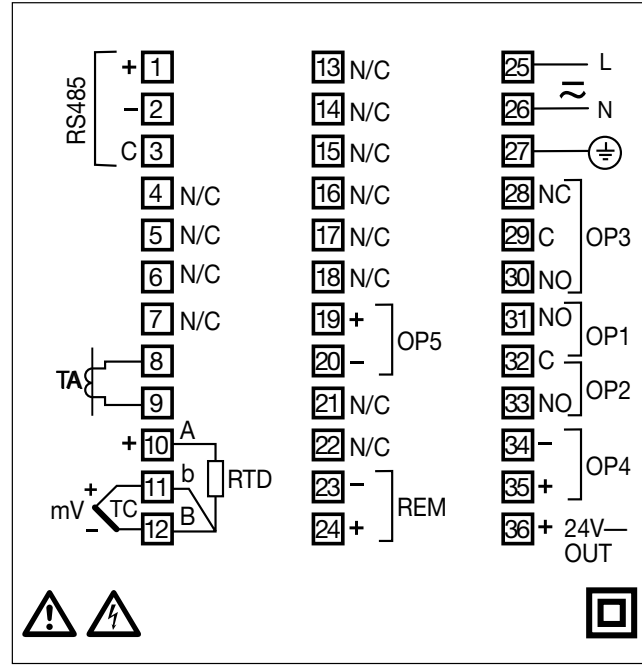

2.1 TERMINATION UNIT

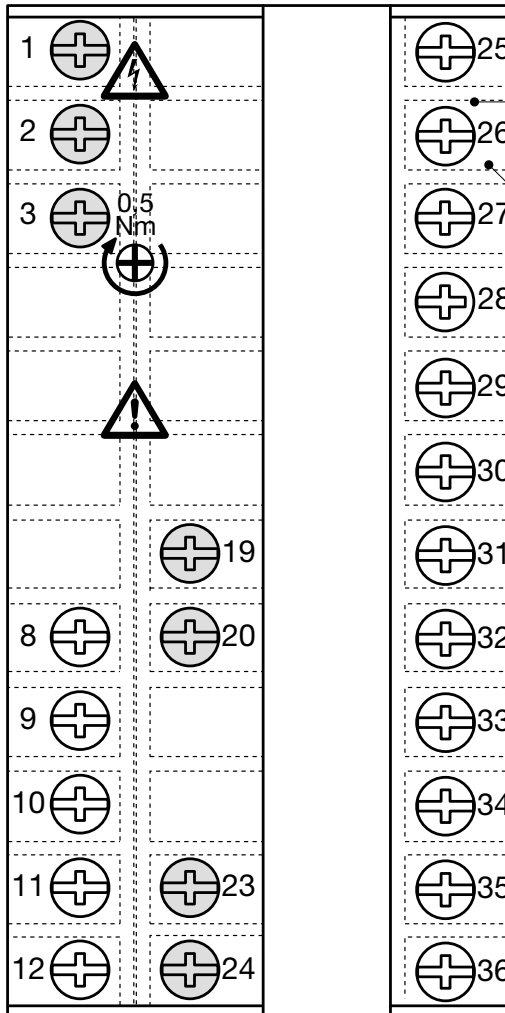

Rear terminal cover

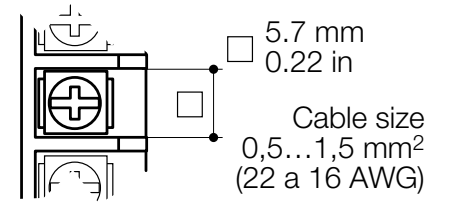

- 24 screw terminals M3
- Option terminals
- Holding screw 0.5 Nm
- Positive screw driver PH1
- Negative screw driver 0,8 x 4 mm

Terminals

- Pin connector
∅ 1.4 mm 0.055 in max
- Fork-shape
AMP 165004
∅ 5.5 mm - 0.21 in
- Stripped wire
L 5.5 mm - 0.21 in

PRECAUTIONS

Despite the fact that the instrument has been designed to work in an harsh and noisy environmental (level IV of the industrial standard IEC 801-4), it is recommended to follow the following suggestions.



All the wiring must comply with the local regulations.

The supply wiring should be routed away from the power cables. Avoid to use electromagnetic contactors, power Relays and high power motors nearby.

Avoid power units nearby, especially if controlled in phase angle

Keep the low level sensor input wires away from the power lines and the output cables.

If this is not achievable, use shielded cables on the sensor input, with the shield connected to earth.

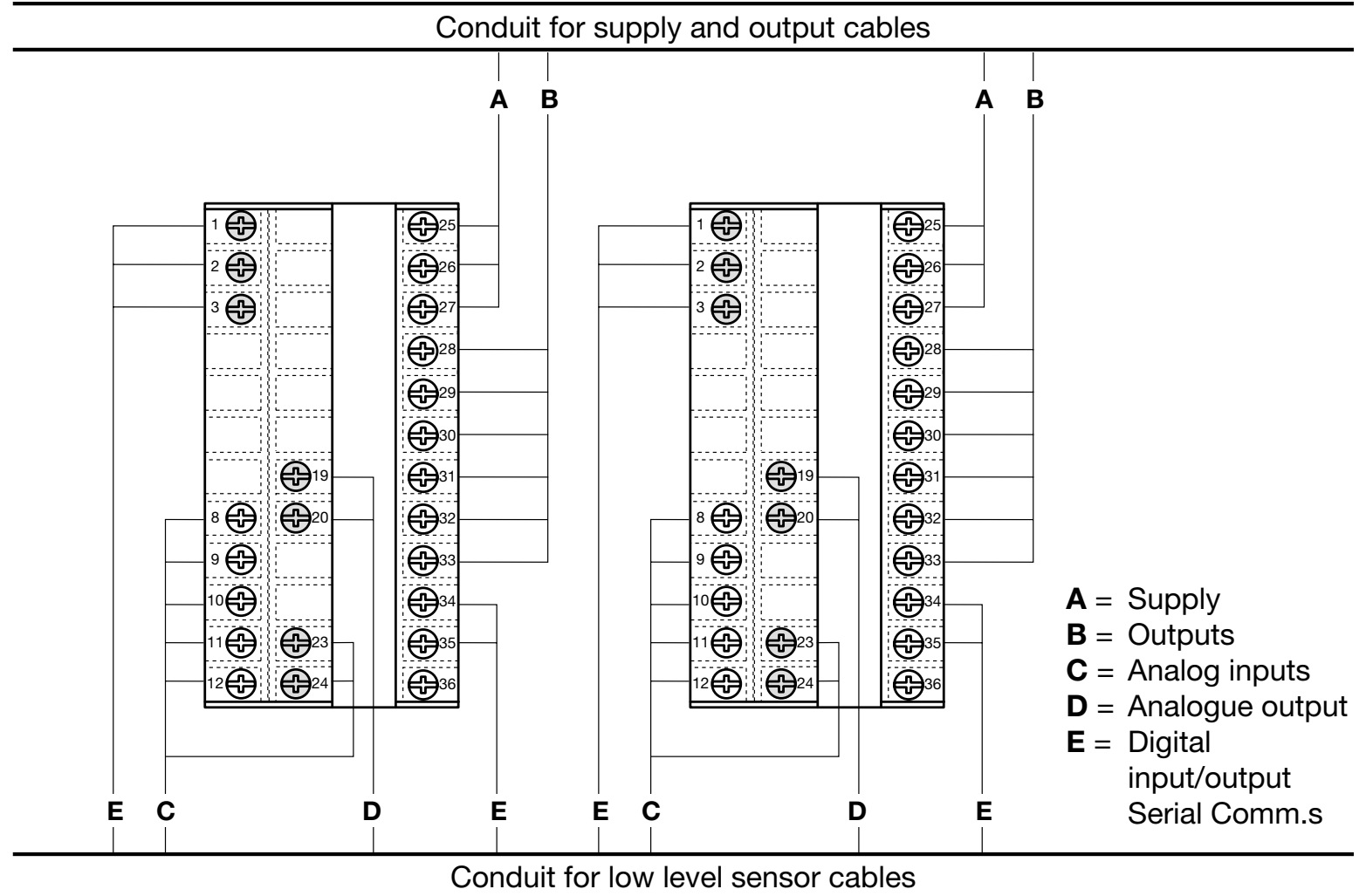
2.2 PRECAUTIONS AND ADVISED CONDUCTOR COURSE

2.3 EXAMPLE OF WIRING DIAGRAM (HEAT / COOL CONTROL)

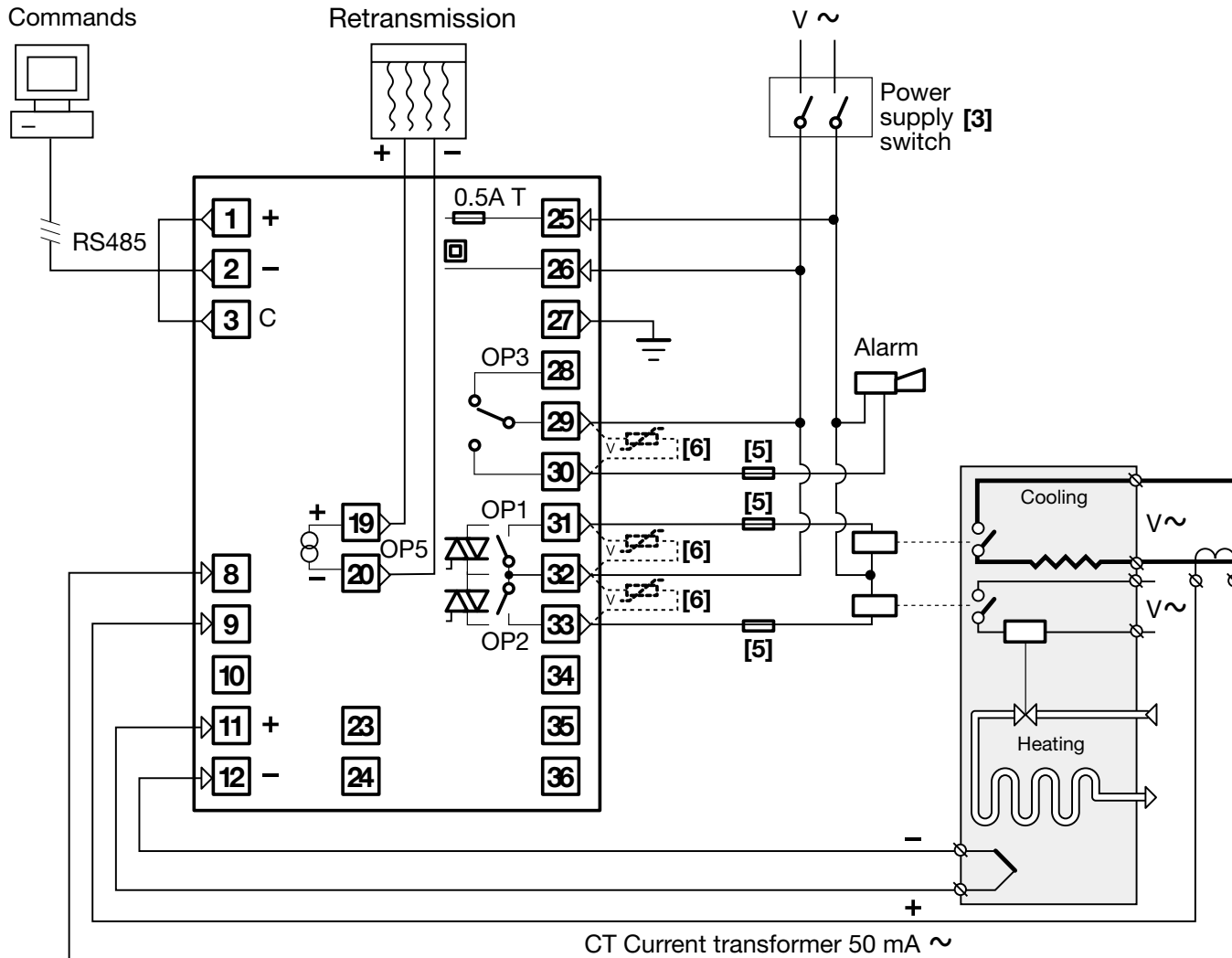

Notes:

- 1] Make sure that the power supply voltage is the same indicated on the instrument.
 - 2] Switch on the power supply only after that all the electrical connections have been completed.
 - 3] In accordance with the safety regulations, the power supply switch shall bring the identification of the relevant instrument. The power supply switch shall be easily accessible from the operator.
 - 4] The instrument is protected with a 0.5 A ~ T fuse. In case of failure it is suggested to return the instrument to the manufacturer for repair.
 - 5] To protect the instrument internal circuits use:
 - 2 A ~ T fuses for Relay outputs
 - 1 A ~ T fuses for Triac outputs
 - 6] Relay contacts are already protected with varistors.
- Only in case of 24 V ~ inductive loads, use model A51-065-30D7 varistors (on request)**

2.3.1 POWER SUPPLY

Switching power supply with multiple isolation and internal fuse

- **Standard version:**
nominal voltage:
100 - 240V~ (- 15% + 10%)
Frequency 50/60Hz
- **Low Voltage version:**
Nominal voltage:
24V~ (- 25% + 12%)
Frequency 50/60Hz
or 24V- (- 15% + 25%)
Power consumption 3VA max

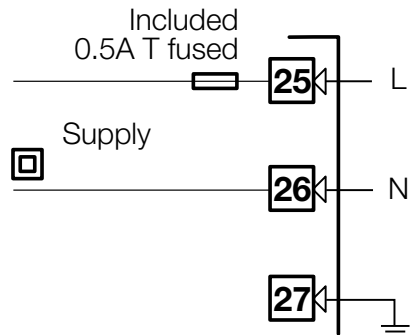

For better protection against noise, it is recommended not to connect the earth clamp provided for civilian installations.

2.3.2 PV CONTROL INPUT

A L-J-K-S-R-T-B-N-E-W thermocouple type

- Connect the wires with the polarity as shown
- Use always compensation cable of the correct type for the thermocouple used
- The shield, if present, must be connected to a proper earth.

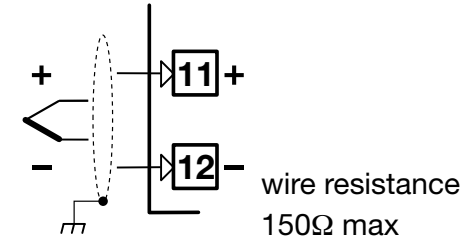

B For Pt100 resistance thermometer

- If a 3 wires system is used, use always cables of the same diameter (1mm² min.) (line 20 Ω/lead maximum resistance)
- When using a 2 wires system, use always cables of the same diameter (1,5mm² min.) and put a jumper between terminals 11 and 12

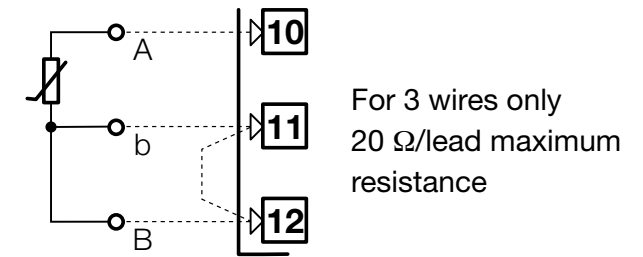

C For ΔT (2x RTD Pt100) Special

- ⚠ When the distance between the controller and the sensor is 15 mt. using a cable of 1.5 mm² diameter, produces an error on the measure of 1°C.

R1 + R2 must be <320Ω

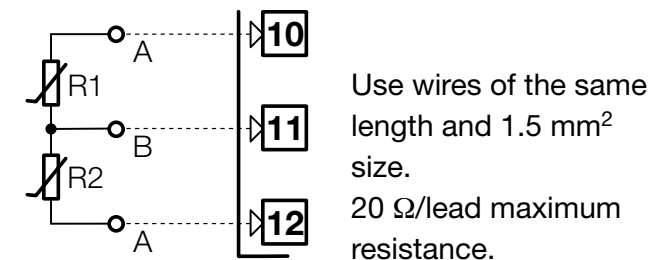

2.3.2 PV CONTROL INPUT



D For mA, mV

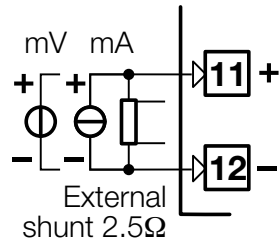

$R_j > 10M\Omega$

D1 With 2 wires transducer

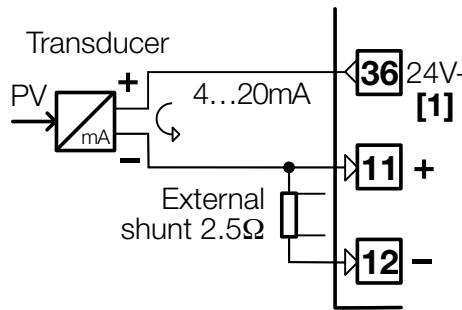

D2 With 3 wires transducer

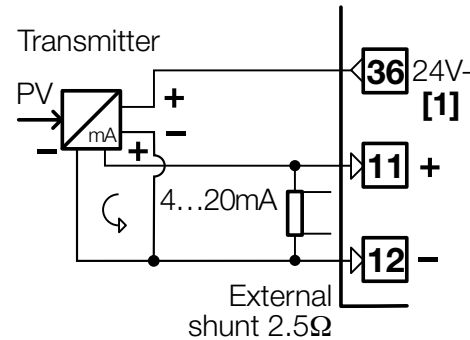

[1] Auxiliary power supply for external transmitter 24V- ±20% /30mA max. without short circuit protection

2.3.3 AUXILIARY INPUT (OPTION)



A - From Remote Setpoint

Current 0/4...20mA
Input resistance = 30Ω

Voltage
1...5V, 0...5V, 0...10V
Input resistance = 300KΩ

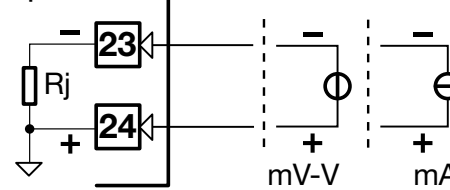

5 watt burden resistor
0.5Ω for 1A secondary transformer coil
0.1Ω for 5A secondary transformer coil

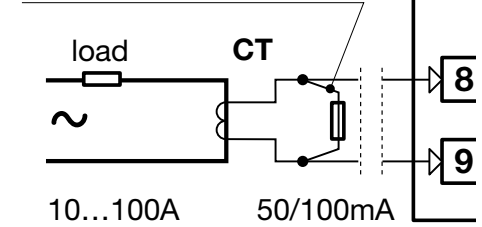

B- For current transformer CT Not isolated

For the measure of the load current (see page 45)

- Primary coil 10A...100A
- Secondary coil 50mA default 100mA **S3** internal jumper selectable

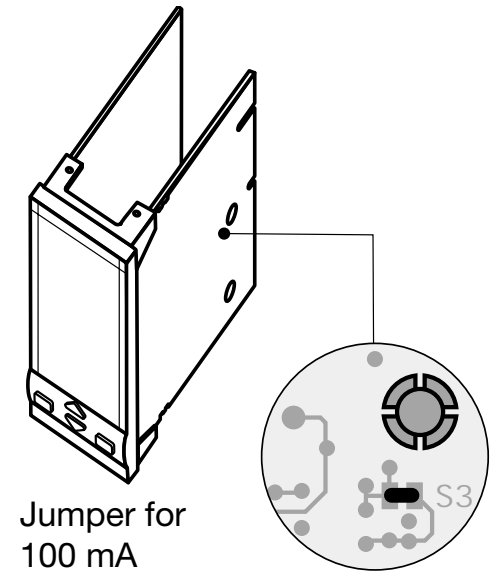

Jumper for 100 mA secondary transformer coil

2.3.5 OP1 - OP2 - OP3 - OP4 - OP5 OUTPUTS (OPTION)



The functionality associated to each of the OP1, OP2 and OP3 output is defined during the configuration of the instrument index **N** (see page 19).

The suggested combinations are:

		Control outputs		Alarms			Retransmission
		Heat	Cool	AL1	AL2	AL3	PV / SP
A	Single action	OP1			OP2	OP3	OP5
B		OP4		OP1	OP2	OP3	OP5
C	Double action	OP1	OP2			OP3	OP5
D		OP1	OP4		OP2	OP3	OP5
E		OP4	OP2	OP1		OP3	OP5

where:

OP1 - OP2	Relay or Triac output
OP3	Relay output (for AL3 only)
OP4	SSR drive control output
OP5	Retransmission analogue output

2.3.5-A SINGLE ACTION RELAY (TRIAC) CONTROL OUTPUT

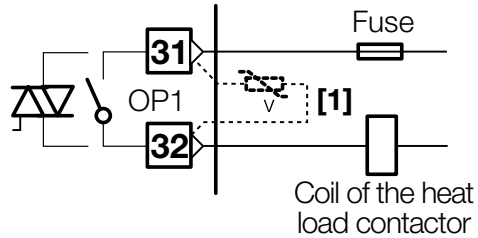

2.3.5-C SINGLE ACTION ANALOGUE OUTPUT

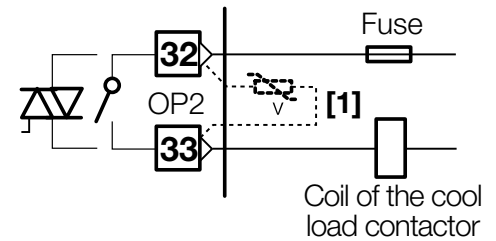
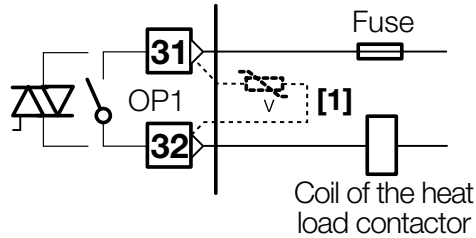

2.3.5-B SINGLE ACTION SSR DRIVE CONTROL OUTPUT

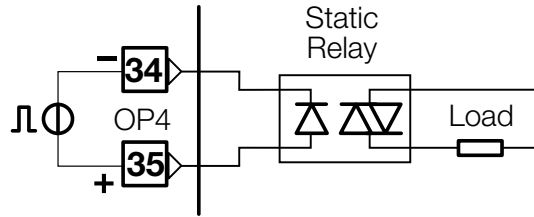

2.3.5-D DOUBLE ACTION RELAY (TRIAC)/RELAY (TRIAC) CONTROL OUTPUT

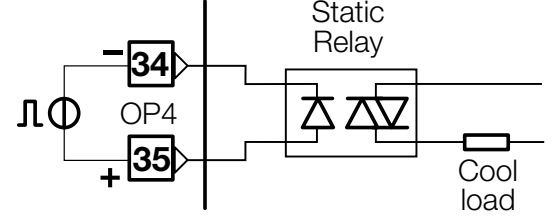
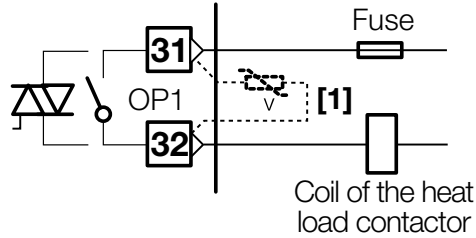

2.3.5-E DOUBLE ACTION RELAY (TRIAC)/SSR DRIVE CONTROL OUTPUT

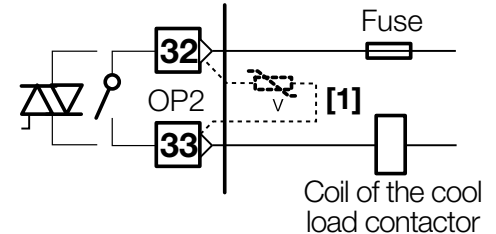
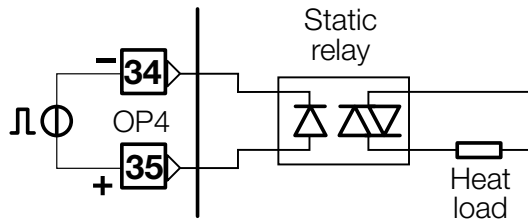

2.3.6 ALARM OUTPUTS



⚠ The relay/triac output OP1, OP2 and OP3, can be used as alarm outputs only if they are not used as control outputs.

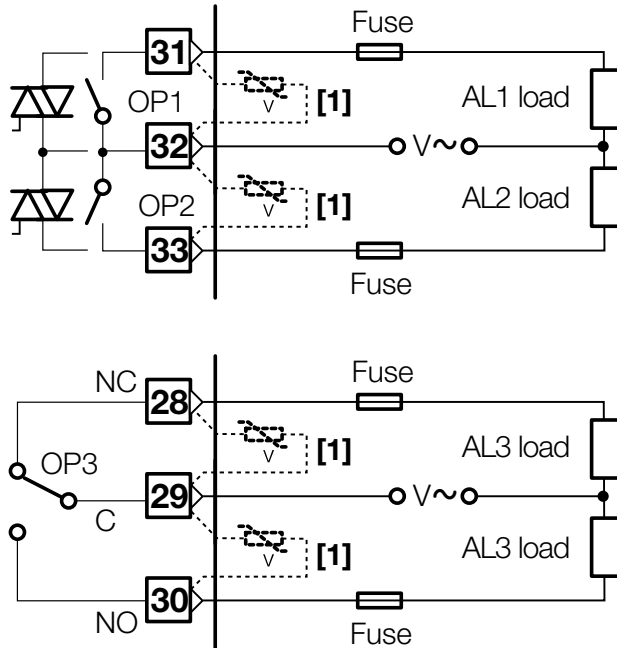

[1] Varistor for inductive load 24V~ only

2.3.7 OP5 ANALOGUE CONTROL OUTPUT (OPTION)

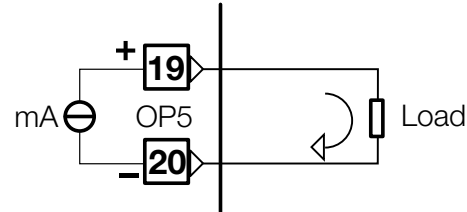

For control or PV/SP retransmission

- Galvanic isolation 500V~/1 min
- 0/4...20mA, (750Ω or 15V- max)

2.3.8 SERIAL COMMUNICATIONS (OPTION)

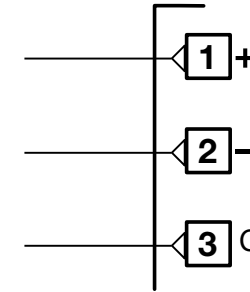

- Galvanic isolation 500V~/1 min
Compliance to the EIA RS485 standard for Modbus/Jbus
- Setting dip switches

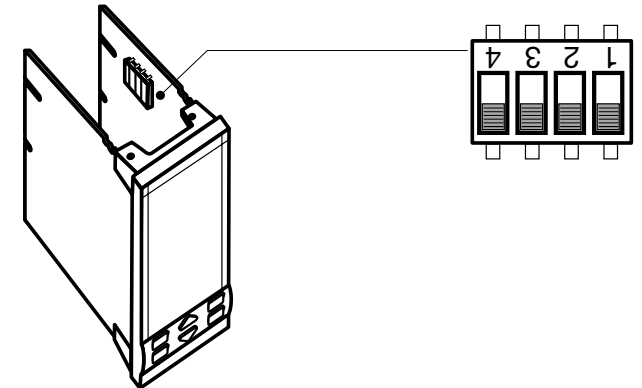

⚠ Please, read the user instructions on the “X1 controller MODBUS/JBUS protocol”

3 PRODUCT CODING

The complete code is shown on the instrument label. The informations about product coding are accessible from the front panel by mean of a particular procedure described at section 5.2 page 47

Configuration code (software)

Basic product code (hardware)

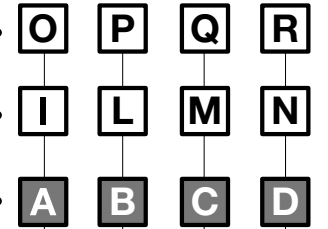

Instrument label

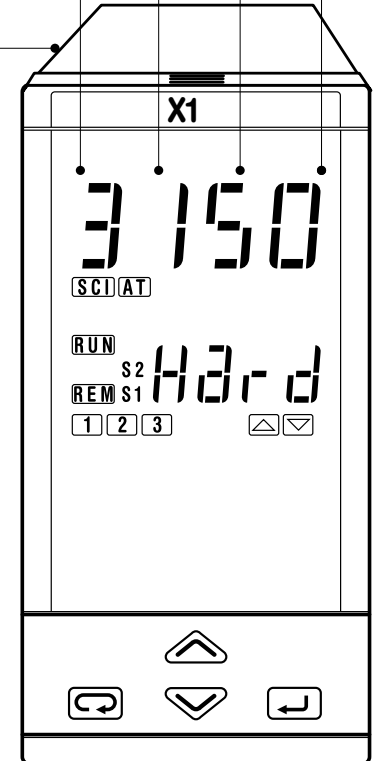
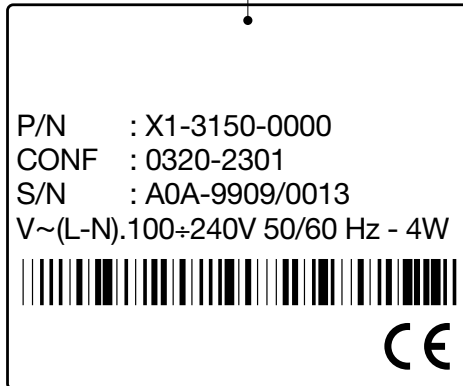

3.1 MODEL CODE

The product code indicates the specific hardware configuration of the instrument, that can be modified by specialized engineers only.



Line **X 1**

Power supply	A
100 - 240V~ (- 15% + 10%)	3
24V~ (- 25% + 12%) or 24V- (- 15% + 25%)	5

Outputs OP1 - OP2	B
Relay - Relay	1
Triac - Triac	5

Serial Communications	C
None	0
RS485 Modbus/Jbus SLAVE	5

Options	D
None	0
Analogue output + Remote Setpoint	5

Setpoint Programmer - special function	E
Not fitted	0
Start-up + Timer	2

User manual	F
Italian/English (std)	0
French/English	1
German/English	2
Spanish/English	3

Front panel colour	G
Dark (std)	0
Beige	1

3.2 CONFIGURATION CODING

A 4+4 index code follows the model of the controller. The code has to be set to configure the controller it. (see chapter 3.1 page 17)

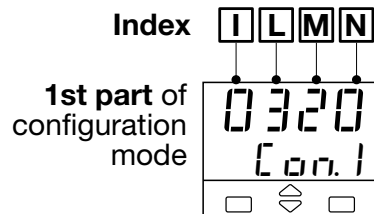

E.g. Enter the code 0320 to choose:

- T/C type J input with range 0...600°C
- Single PID control algorithm , reverse action
- Relay output

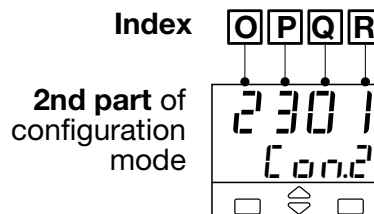

E.g. Enter the code 2301 to choose:

- AL1 absolute, active high
- AL2 absolute, active low
- AL3 Used by Timer
- Local + 2 Stored Setpoints with tracking function

Input type and range	I	L	
TR Pt100 IEC751	-99.9...300.0 °C	-99.9...572.0 °F	0 0
TR Pt100 IEC751	-200...600 °C	-328...1112 °F	0 1
TC L Fe-Const DIN43710	0...600 °C	32...1112 °F	0 2
TC J Fe-Cu45% Ni IEC584	0...600 °C	32...1112 °F	0 3
TC T Cu-CuNi	-200 ...400 °C	-328...752 °F	0 4
TC K Cromel-Alumel IEC584	0...1200 °C	32...2192 °F	0 5
TC S Pt10%Rh-Pt IEC584	0...1600 °C	32...2912 °F	0 6
TC R Pt13%Rh-Pt IEC584	0...1600 °C	32...2912 °F	0 7
TC B Pt30%Rh Pt6%Rh IEC584	0...1800 °C	32...3272 °F	0 8
TC N Nicrosil-Nisil IEC584	0...1200 °C	32...2192 °F	0 9
TC E Ni10%Cr-CuNi IEC584	0...600 °C	32...1112 °F	1 0
TC NI-NiMo18%	0...1100 °C	32...2012 °F	1 1
TC W3%Re-W25%Re	0...2000 °C	32...3632 °F	1 2
TC W5%Re-W26%Re	0...2000 °C	32...3632 °F	1 3
Dc input 0...50mV linear	Engineering and units		1 4
Dc input 10...50mV linear	Engineering and units		1 5
Custom input and range [1]			1 6

[1] For instance, other thermocouples types, ΔT (with 2 PT 100), custom linearisation etc.

Engineering and units		M
ON-OFF reverse action		0
ON-OFF direct action		1
P.I.D. single reverse action		2
P.I.D. single direct action		3
P.I.D. double action	Linear cool output	4
	ON-OFF cool output	5
	Water cool output [2]	6
	Oil cool output [2]	7

Output configuration		N
Single action	Double action	
Relay	Heat Relay, Cool Relay	0
SSR drive	Heat Relay, Cool SSR drive	1
	Heat SSR drive, Cool Relay	2

[2] In consideration of the thermal characteristics of the different cooling liquids, 2 different correcting methods of the control output are available. One for water and the other for oil

$$OP \text{ water} = 100 \cdot (OP2/100)^2$$

$$OP \text{ oil} = 100 \cdot (OP2/100)^{1.5}$$

[3] Only possible whether "Output configuration" **N** = 0 or 1) and *H.E.F.5.* parameter is different to *OFF*, see page 29)

Alarm 1 type and function		O
Disabled		0
Sensor break/Loop break alarm (LBA)		1
Absolute	active high	2
	active low	3
Deviation	active high	4
	active low	5
Band	active out	6
	active in	7
Heater break by CT [3]	active during ON output state	8
	active during OFF output state	9

Alarm 2 type and function		P
Disabled		0
Sensor break/Loop break alarm (LBA)		1
Absolute	active high	2
	active low	3
Deviation	active high	4
	active low	5
Band	active out	6
	active in	7
Heater break by CT [3]	active during ON output state	8
	active during OFF output state	9

3 - Product coding

Alarm 3 type and function		Q
Disabled or used by Timer		0
Sensor break/Loop break alarm (LBA)		1
Absolute	active high	2
	active low	3
Deviation	active high	4
	active low	5
Band	active low	6
	active in	7
Heater break by CT [3]	active during ON output state	8
	active during OFF output state	9

Setpoint type		R
Local only		0
Local and 2 tracking stored Setpoints		1
Local and 2 Stand-by stored Setpoints		2
Local and Remote		3
Local with trim		4
Remote with trim		5

4 OPERATIONS

4.1.1 KEYS FUNCTIONS AND DISPLAY IN OPERATOR MODE

8 Status LEDs (greens)

- SCI** Communications running
- AT** Tuning running
- RUN** Timer/Program running
- REM** Remote Setpoint active
- S1** First stored Setpoint active
- S2** Second stored Setpoint active

Alarm status LEDs (reds)

- 1** AL1 ON
- 2** AL2 ON
- 3** AL3 ON

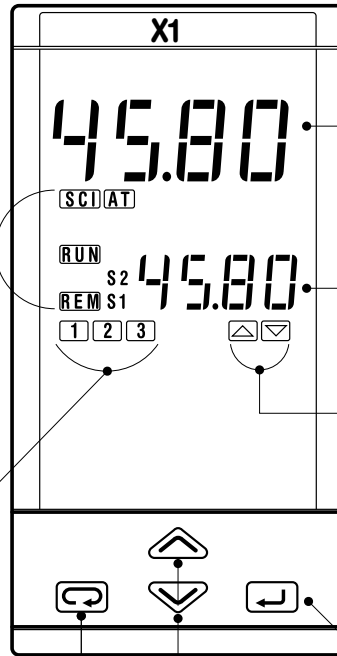

PV control input
in engineering
units



SP operating Setpoint
(Local/Remote or Stored)

Control output LEDs (red)

▲ OP1/OP4 ON - ▼ OP2/OP4 OFF

Entry key for selection and value setting confirmation



Setpoint setting

Menu access



4.1.2 KEYS FUNCTIONS AND DISPLAY IN PROGRAMMING MODE



The parameter setting procedure has a timeout. If no keys are pressed for, at least, 30 seconds, the controller switches back, automatically, to the operator mode.

After having selected the parameter or the code, press  and  to display or modify the value (see page 23)

The value is entered when the next parameter is selected, by pressing the  key.

Until the  or  are pressed or if you wait for 30 seconds the parameter value is not inserted

Pressing the  key, the next group of parameters is presented on the display.

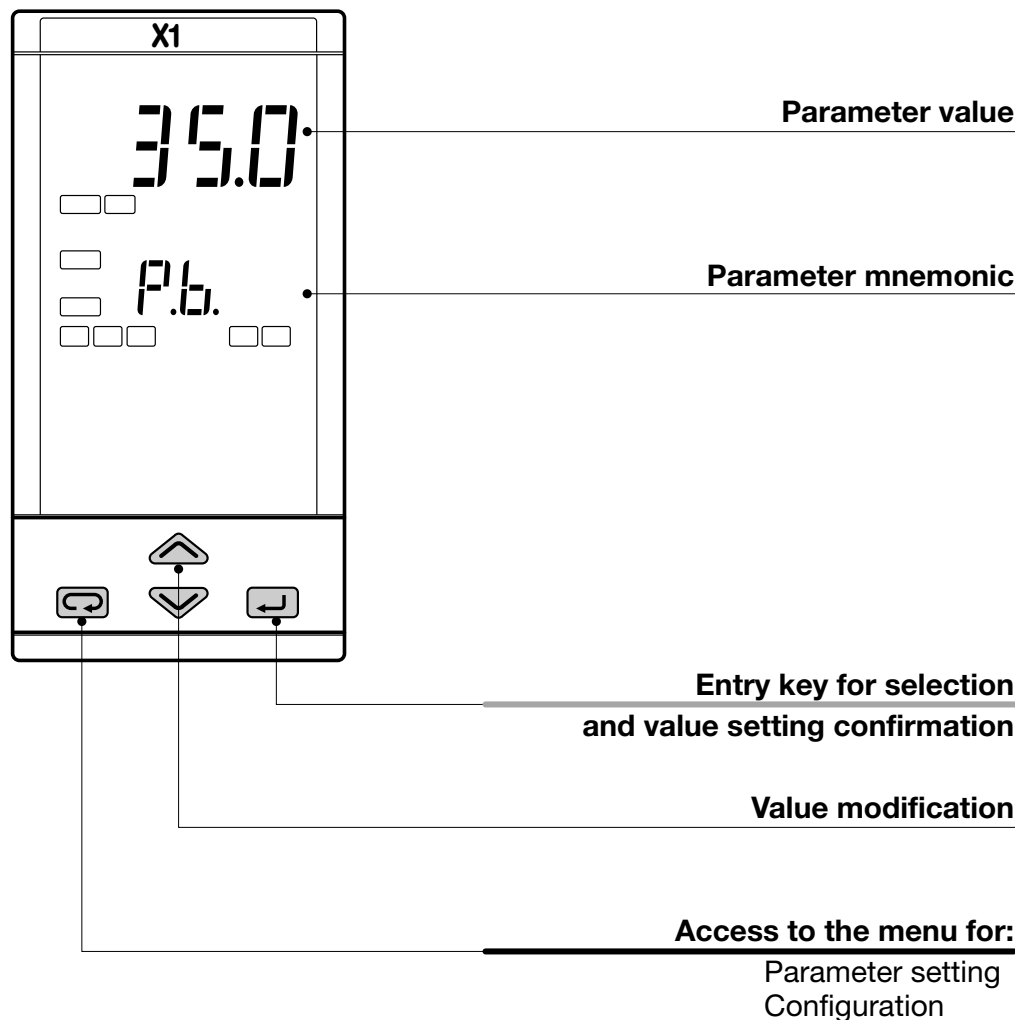

4.2 PARAMETER SETTING

4.2.1 NUMERIC ENTRY

(i.e. the modification of the Setpoint value from 275.0 to 240.0)

Press or momentarily to change the value of 1 unit every push

Continued pressing of or changes the value, at rate that doubles every second. Releasing the button the rate of change decreases.

In any case the change of the value stops when it has reached the max/min limit set for the parameter.

In case of Setpoint modification: press or once to display the local Setpoint instead of working Setpoint.

To evidence this change the display flashes once. Then the Setpoint can be modified

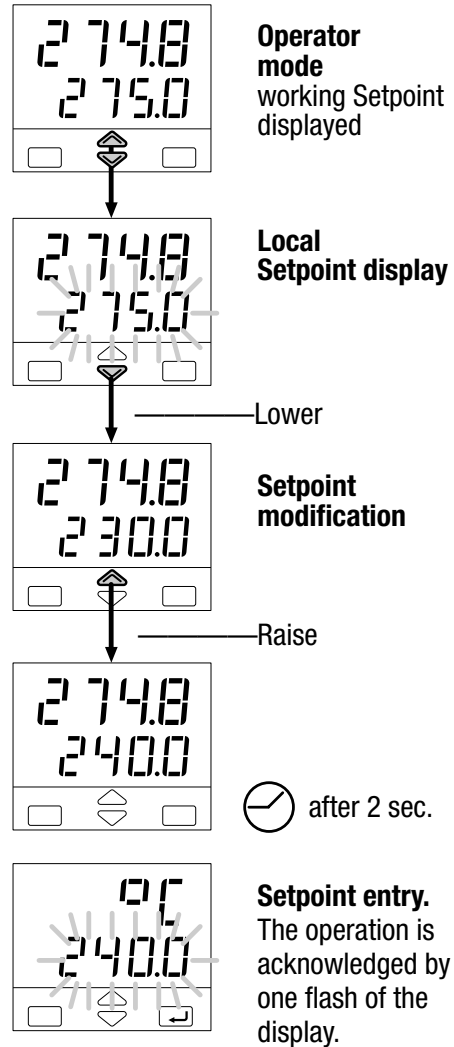

4.2.2 MNEMONIC CODES SETTING

(e.g. configuration see page 28)

Press the or to display the next or previous mnemonic for the selected parameter.

Continued pressing of or will display further mnemonics at a rate of one mnemonic every 0.5 sec. The mnemonic displayed at the time the next parameter is selected, is the one stored in the parameter.

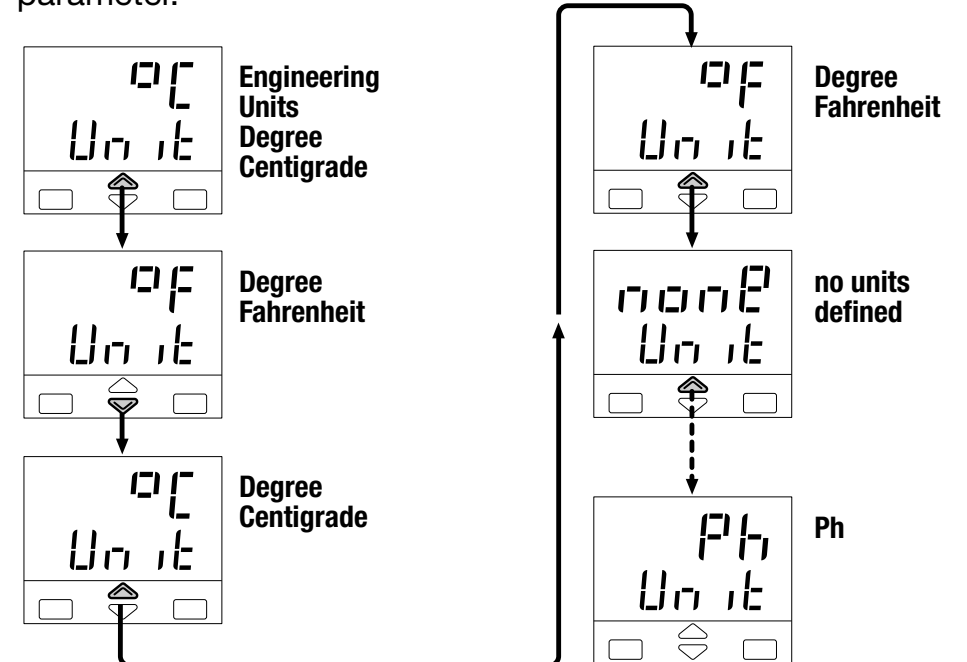

4.3 PARAMETERISATION - MAIN MENU

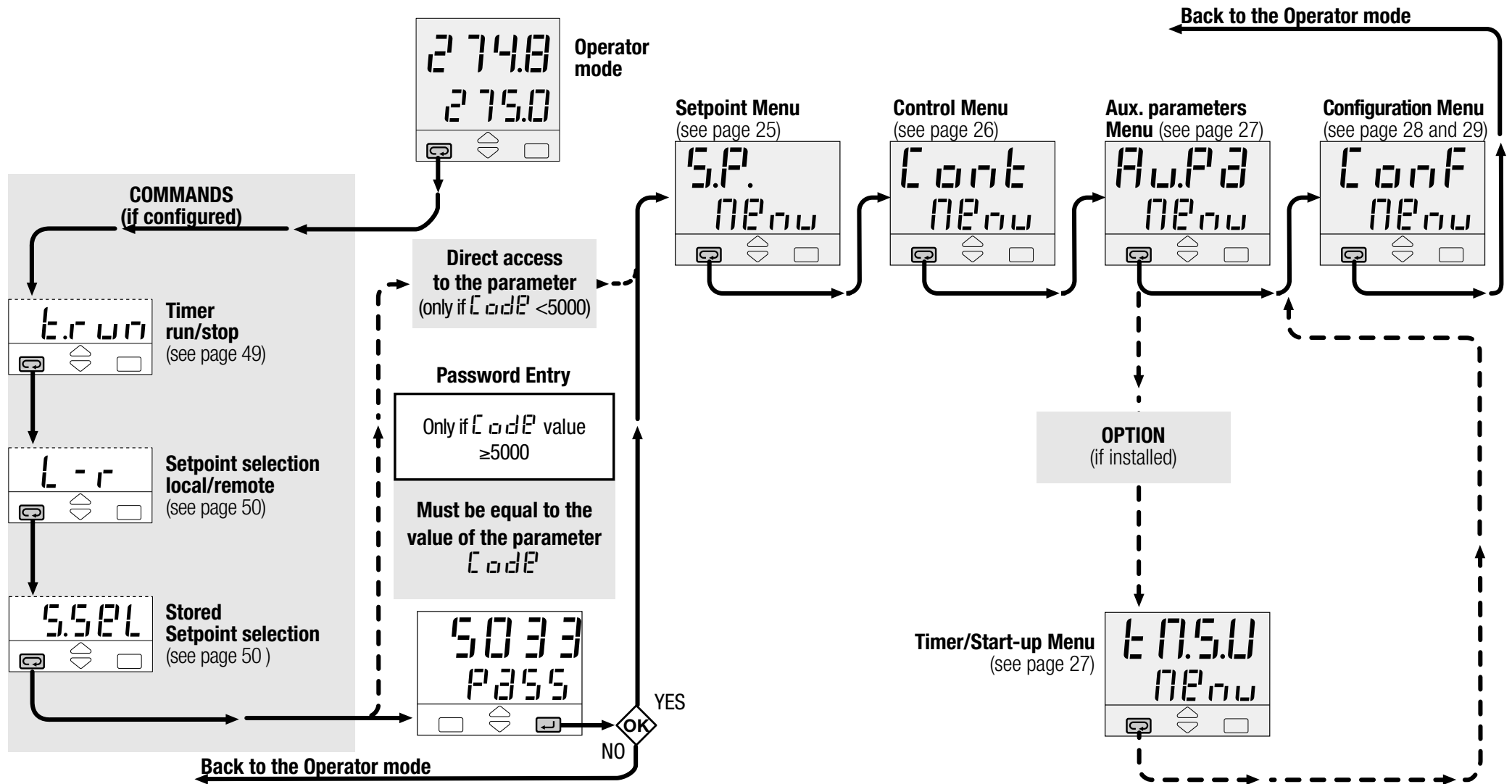

4.3.1 PARAMETERISATION - SETPOINT MENU

Menu Setpoint



AL1 alarm threshold [1]
(see page 30)

0

A 15.P

AL2 alarm threshold [1]
(see page 30)

0

A 25.P

AL3 alarm threshold [1]
(see page 30)

0

A 35.P

Setpoint ramp up
OFF / 0.1 ... 999.9
digit/min

OFF

SL. u

Setpoint ramp down
OFF / 0.1 ... 999.9
digit/min

OFF

SL. d

L.range

Setpoint low limit low
range...S.P. H

S.P. L

H.range

Setpoint high limit
S.P. L ...High range

S.P. H

Note
[1] It is not presented if the controller has been configured with alarm n° 2 not active or of sensor break type. Digit O/P of the configuration code is assigned to 0 or 1.

LOCAL, REMOTE, PROGRAMM.
configuration index **R** = 0, 3, 6

LOCAL, + 2 STORED.
configuration index **R** = 1, 2

LOCAL OR REMOTE WITH TRIM.
configuration index **R** = 4, 5

.....

S.P. 1

1st stored Setpoint

.....

S.P. 2

1nd stored Setpoint

.....

rt 10

Ratio Setpoint

.....

b 125

Remote Setpoint bias

4.3.2 PARAMETERISATION - CONTROL MENU

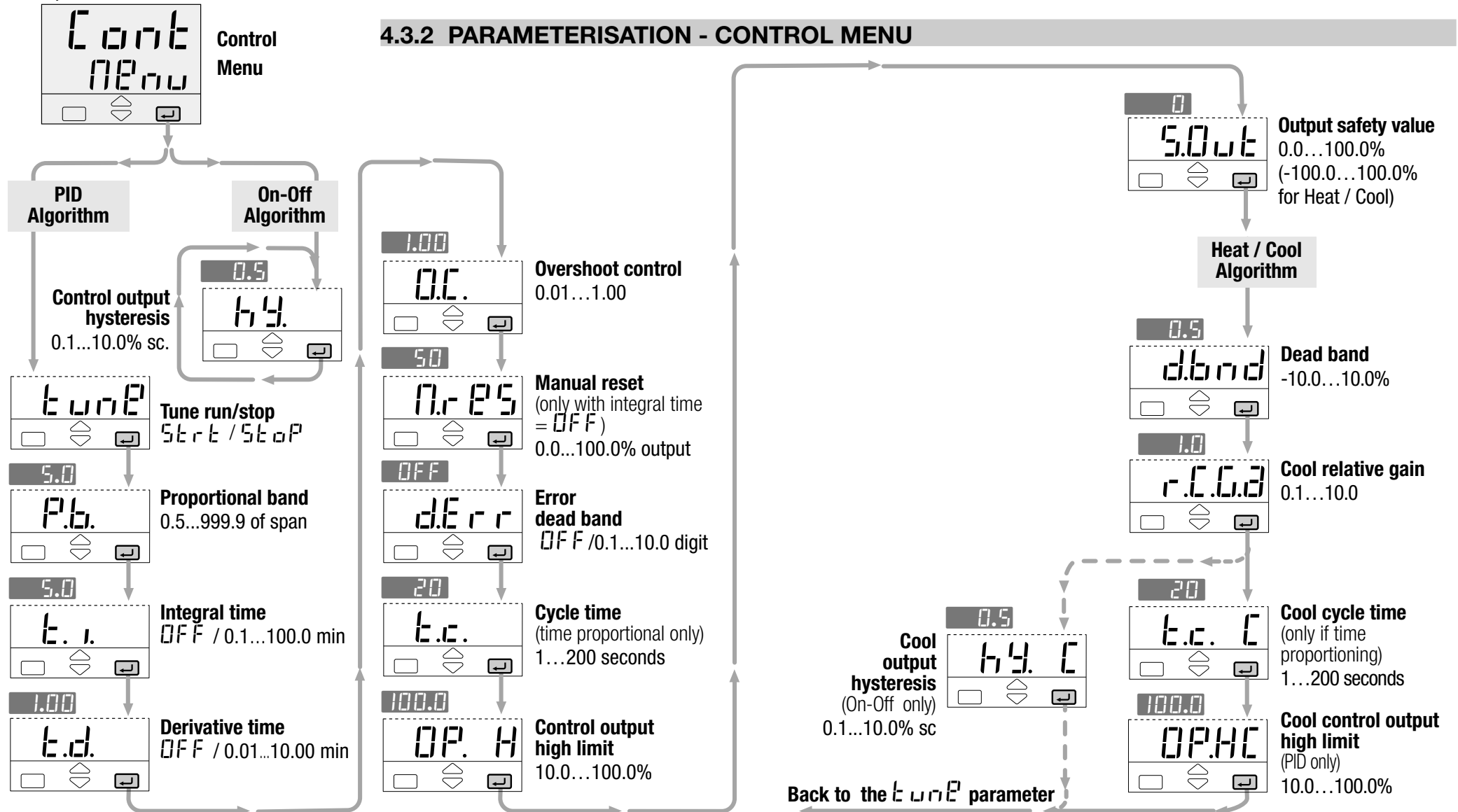

4.3.3 PARAMETERISATION - AUXILIARY PARAMETERS MENU

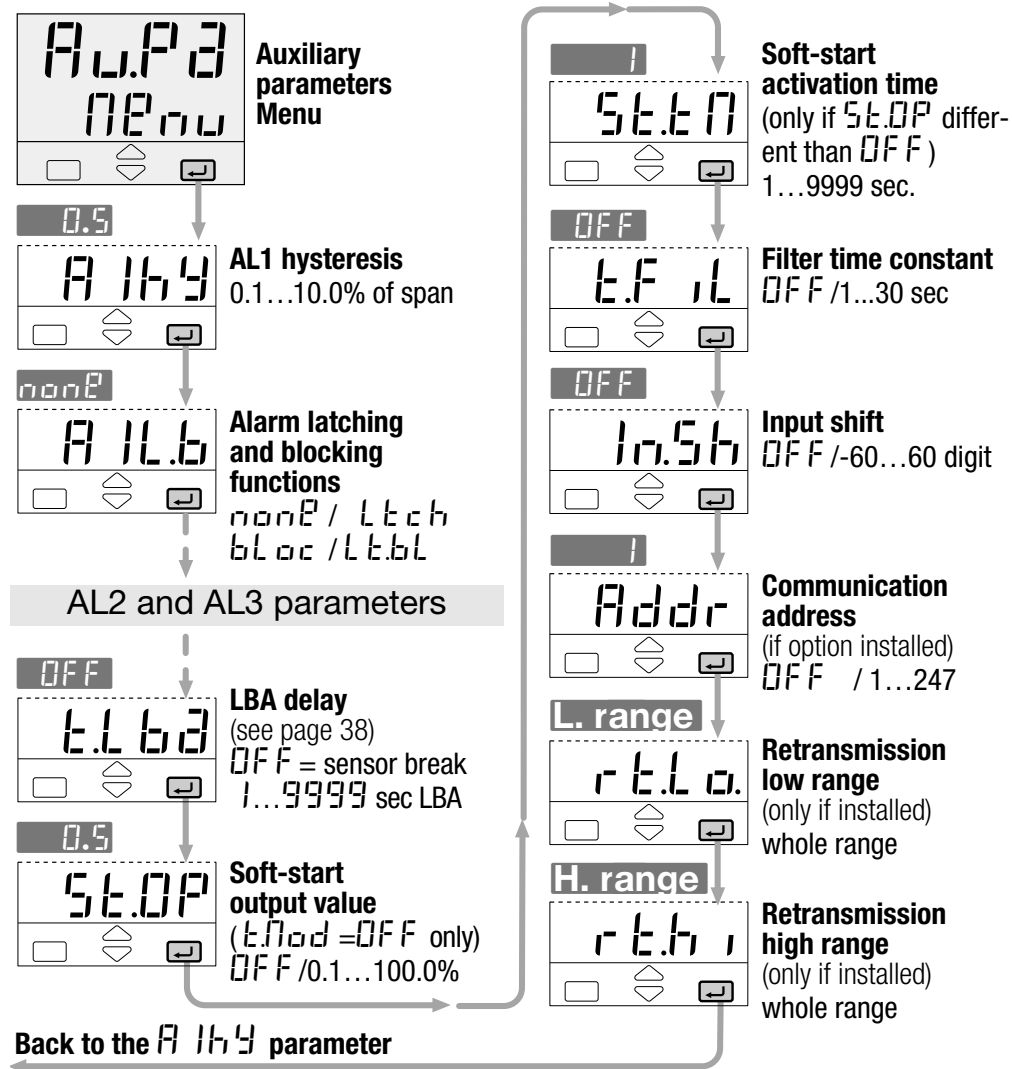

4.3.4 PARAMETERISATION - TIMER AND START-UP MENU

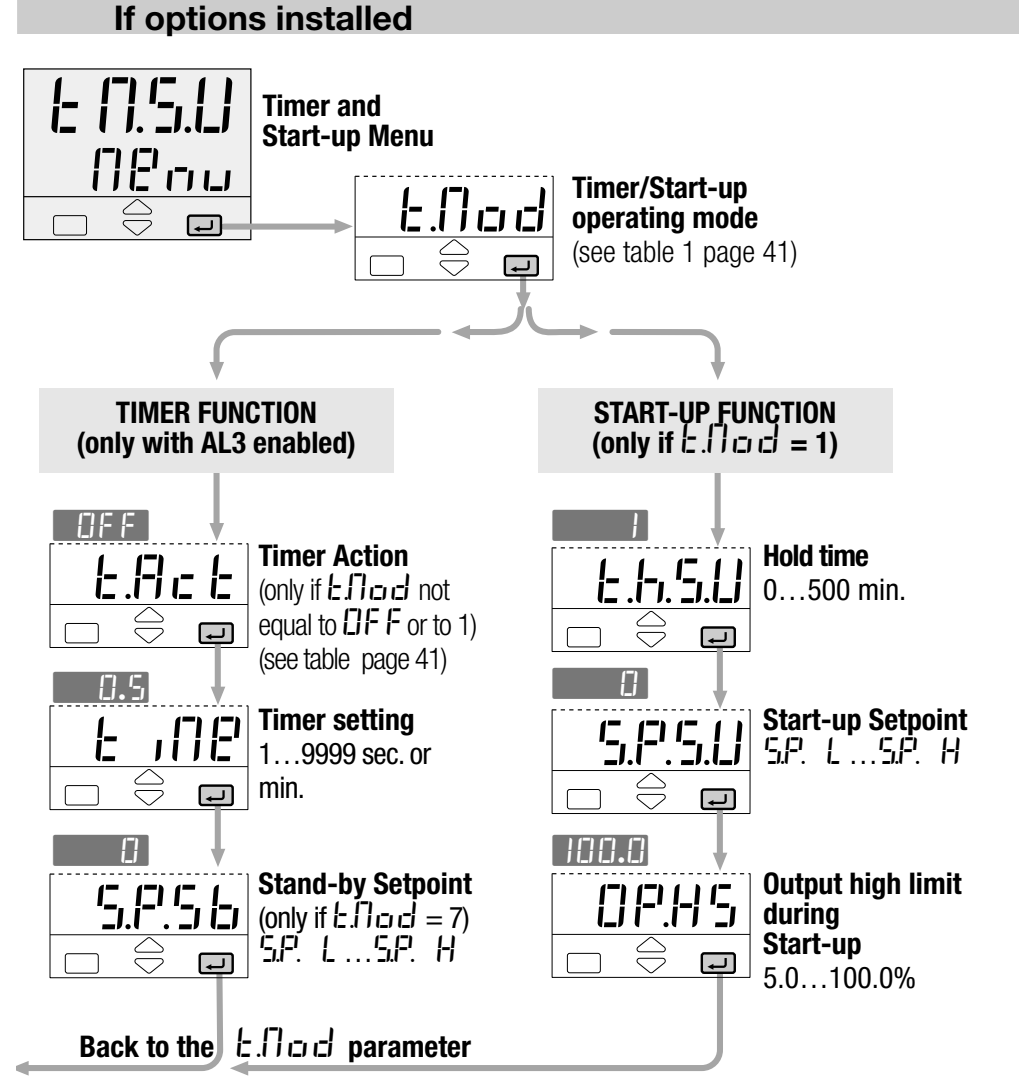

4.3.5 CONFIGURATION MENU

Enter the password before accessing to the configuration menu.

If a not configured controller is supplied, when powered up for the first time, the display shows:

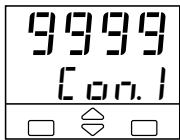

Until the configuration code is set correctly, the controller remains in stand-by with input and output deactivated.

A 4+4 index code follows the model of the controller. It has to be set to configure the controller. (see chapter 3.1 page 17)

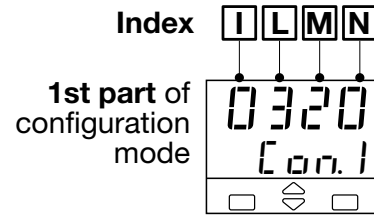

E.g. Enter the code 0320 to choose:

- T/C type J input with range 0...600°C
- Single PID control algorithm , reverse action
- Relay output

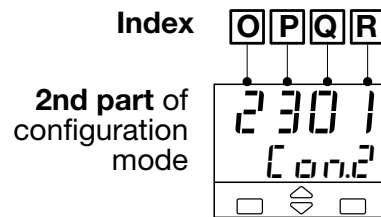

E.g. Enter the code 2301 to choose:

- AL1 absolute, active high
- AL2 absolute, active low
- AL3 Used by Timer
- Local + 2 Stored Setpoints with Tracking function

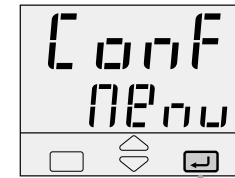

Password Entry

Only if `Code` value < 5000
(33 default from factory)

Must be equal to the value of the parameter `Code`

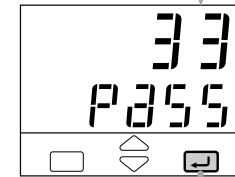

Entry of digits I - L - M - N of the configuration code (chapter 3.2 pages 18, 19)



Entry of digits O - P - Q - R of the configuration code (chapter 3.2 pages 19, 20)

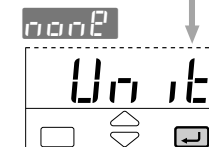

IL1 digital input function (see table 1)

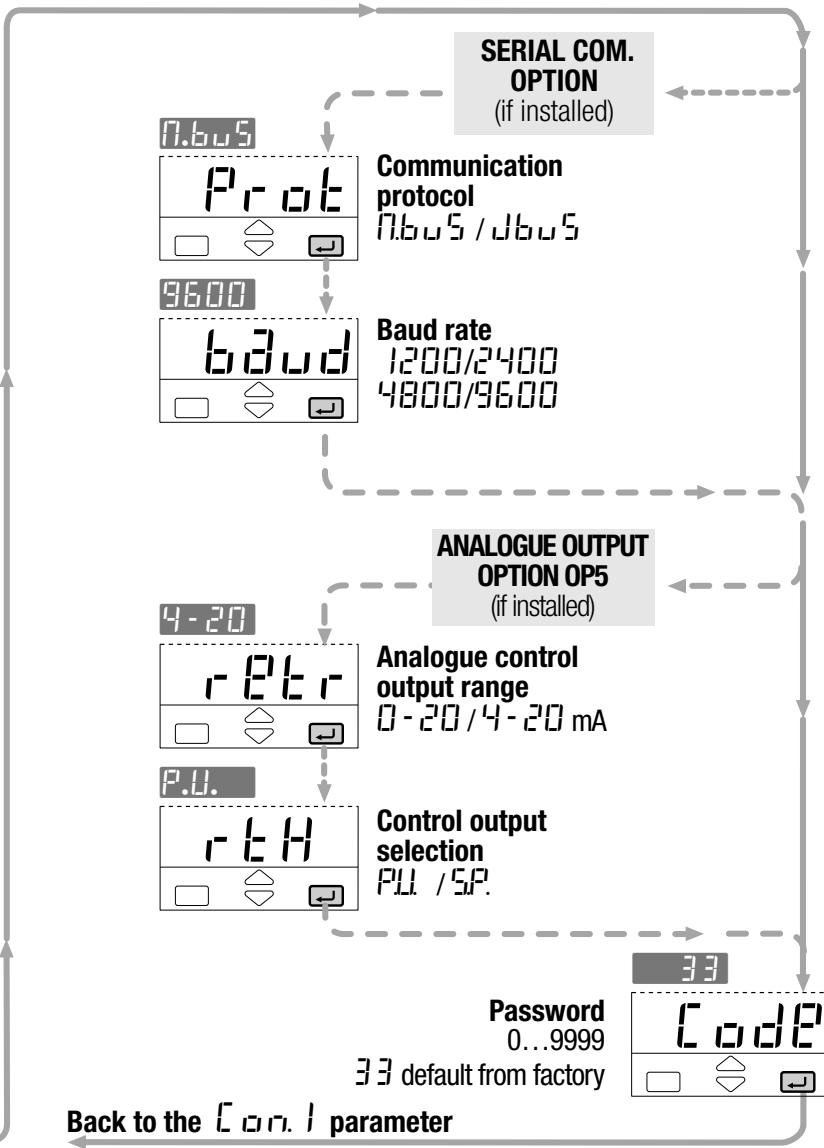
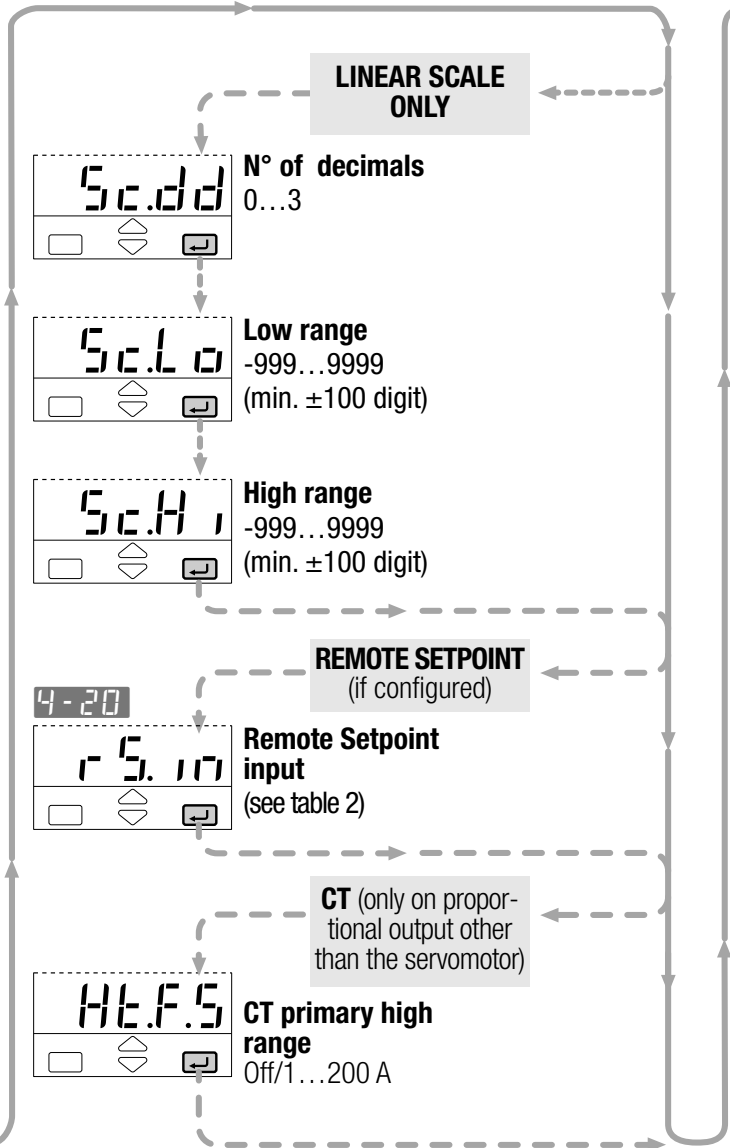

Table 1 Engineering units

unit	
Value	Description
°C	degree centigrade
°F	degree Fahrenheit
none	none
mV	mV
V	Volt
mA	mA
A	Ampere
bar	Bar
PSI	PSI
Rh	Rh
pH	pH

Table 2 Remote Setpoint input type

r S. i n	
Value	Description
0-5	0...5 Volt
1-5	1...5 Volt
0-10	0...10 Volt
0-20	0...20 mA
4-20	4...20 mA

4.4 PARAMETERS

For a simpler use of the controller, its parameters have been organised in groups (menu), according to their functionality area.

4.4.1 SETPOINT MENU

The OP1, OP2 or OP3 outputs, can be used for alarms if they are not used as control outputs

It is possible to configure up to 4 alarms: AL1, AL2, AL3, AL4 (see page 19 and 20), selecting, for each of them:

- A** the type and the operating condition of the alarm
- B** the functionality of the alarm acknowledge (latching) `L E C H` (see page 37)
- C** the start-up disabling (blocking) `b L o c` (see page 37)
- D** Loop break or sensor break (see page 38)

A ALARM TYPE AND OPERATION CONDITIONS

Absolute alarm (full scale)

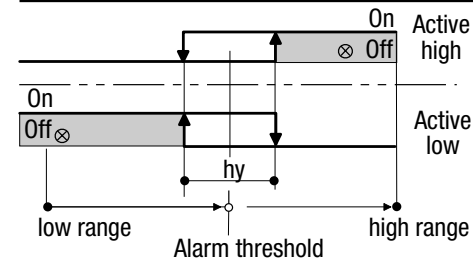

Deviation alarm

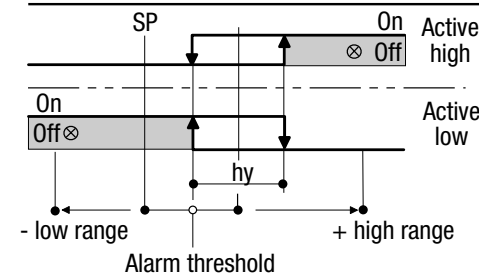

Band alarm

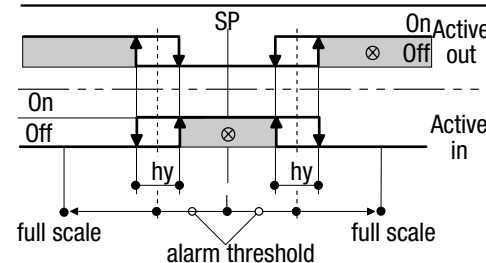

A 15.P

AL1 alarm threshold

A 25.P

AL2 alarm threshold

A 35.P

AL3 alarm threshold

Alarm occurrences of OP1, OP2 and OP3 outputs, respectively linked to AL1, AL2 and AL3.

The range of the alarm threshold correspond to the whole span and it is not limited by the SP Setpoint span.

When the event occurs, the display will show the red leds `1`, `2` or `3`, respectively on.

SL. u

**Setpoint
ramp up**

SL. d

**Setpoint
ramp down**

This parameter specifies the maximum rate of change of the Setpoint in digit/min.

When the parameter is OFF, this function is disabled and the new Setpoint is reached immediately after being entered.

Otherwise, the Setpoint value is reached according to the configured rate of change.

The new Setpoint value is called "Target Setpoint". It can be displayed by means the parameter **ESP.** (see procedure at page 47).

When Remote Setpoint is configured, we suggest to disable **SL. u** and **SL. d** parameters **OFF**.

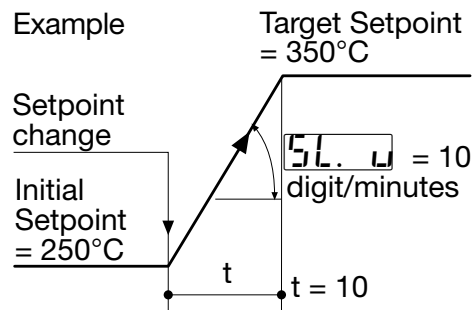

SP. L

**Setpoint
low limit**

SP. H

**Setpoint
high limit**

Low / high limit of the Setpoint value.

SP. 1

**1st stored
Setpoint**

SP. 2

**2nd stored
Setpoint**

Preset Set values can be set from the keyboard and serial communication. The Setpoint active is indicated by the **S1** or **S2** green led.

If index **R** = 1 (tracking), the previous Local Setpoint value will be lost, when the stored Setpoint is selected.

If index **R** = 2 (Stand-by), the Local Setpoint value will not be lost, when the Stand-by Setpoint is selected. It will operate again when back to Local.

See stored Setpoint selection procedure at page 50

4.4.1 SETPOINT MENU

rt 10

Remote Setpoint Ratio

Ratio is the coeff. which defines the remote Setpoint span with respect to the input span.

b 125

Remote Setpoint

Bias defines the starting point of analogue Remote Setpoint in eng. units corresponding to the low limit (current or voltage) of the remote signal.

Remote Setpoint Bias and Ratio

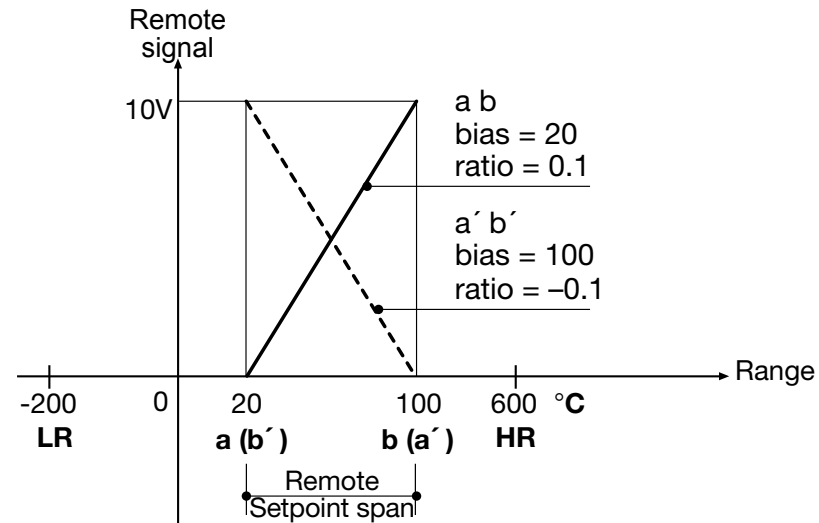

PV = process variable
 LR = PV low limit
 HR = PV high limit
 SR = Remote Setpoint
 a (a') = SR starting point
 b (b') = SR ending point

If SR starting point is **lower** than the ending point, both expressed in engineering units:

b 125 = starting point = a

$$rt 10 = \frac{b - a}{HR - LR}$$

Example:

b 125 = 20

rt 10 =

$$\frac{100 - 20}{600 - (-200)} = \frac{80}{800} = 0.1$$

If SR starting point is **higher** then the ending point, both expressed in engineering units

$b_{\text{set}} = \text{starting point} = a'$

$$r_{\text{trim}} = \frac{b' - a'}{HR - LR}$$

Example:

$b_{\text{set}} = 100$

$$r_{\text{trim}} = \frac{20 - 100}{600 - (-200)} = \frac{-80}{800} = -0.1$$

Working Setpoint (SP) as combination of Local Setpoint (SL) and remote signal

Setpoint type *Local*
(configuration index **R** = 4)

$$SP = SL + (r_{\text{trim}} \cdot REM) + b_{\text{set}}$$

Setpoint type *Remote*
(configuration index **R** = 5)

$$SP = REM + (r_{\text{trim}} \cdot SL) + b_{\text{set}}$$

SIGN = Remote signal percentage

SPAN = HR-LR

$$REM = \frac{SIGN * SPAN}{100}$$

Examples:

Local Setpoint (SL) with an external Trim with multiplying coeff. of 1/10:

Setpoint type = *Local*

$r_{\text{trim}} = 0.1$

$b_{\text{set}} = 0$

Remote Setpoint (SR) with an internal Trim with multiplying coeff. of 1/5:

Setpoint type = *Remote*

$r_{\text{trim}} = 0.2$

$b_{\text{set}} = 0$

Remote Setpoint range equal to the input range:

Setpoint type = *Local*

$r_{\text{trim}} = 1$

$b_{\text{set}} = LR$

$SL = 0$

4.4.2 CONTROL MENU



Run
Tune

4.4.2.1 AUTOMATIC TUNE

The **Fuzzy-Tuning** determines automatically the best PID term with respect to the process behaviour.

The controller provides 2 types of “one shot” tuning algorithm, that are selected automatically according to the process condition when the operation is started.

This type is selected when, at

STEP response

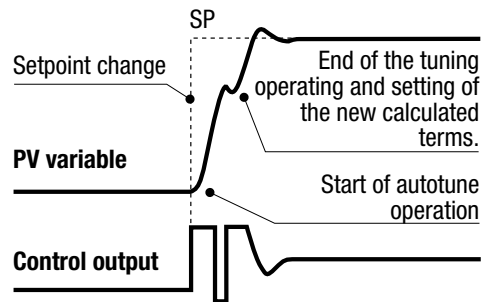

the start of the autotune operation, the PV is far from the Setpoint of more than 5% of the span. This method has the big advantage of fast calculation, with a reasonable accuracy in the term calculation.

Natural frequency

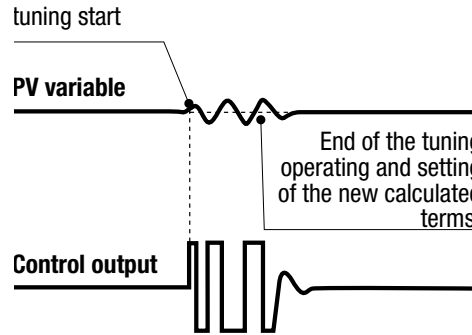

This type is selected when the PV is close to the SP Setpoint. This method has the advantage of a better accuracy in the term calculation with a reasonable speed calculation.

The **Fuzzy Tuning** determines automatically the best method to use to calculate the PID term, according the process conditions.

FUZZY-TUNING START/STOP PROCEDURE

Start/stop of the Fuzzy Tuning
The Tuning operation can be started or stopped any time.

The green led **[AT]** is ON when the Fuzzy Tuning is in progress. At the end of this operation, the calculated PID terms parameter are stored and used by the control algorithm and the controller goes back to the operator mode. The green led **[AT]** becomes off.

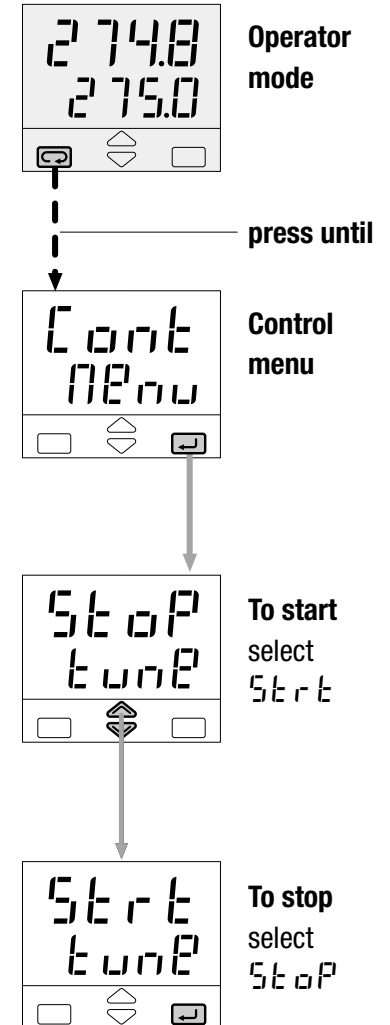

P.b. Proportional band

This parameter specifies the proportional band coefficient that multiplies the error (SP - PV)

I. I. Integral time

It is the integral time value, that specifies the time required by the integral term to generate an output equivalent to the proportional term. When *OFF* the integral term is not included in the control algorithm.

I.d. Derivative time

It is the time required by the proportional term P to repeat the output provided by the derivative term D. When *OFF* the derivative term is not included in the control algorithm.

O.C. Overshoot control

This parameter specifies the span of action of the overshoot control. Setting lower values (1.00 → 0.01) the overshoot generated by a Setpoint change is reduced. The overshoot control doesn't affect the effectiveness of the PID algorithm. Setting 1, the overshoot control is disabled.

M.r. R.S Manual Reset

This specifies the control output value when PV = SP, in a PD only algorithm (lack of the integral term).

d.E.r.r Error Dead Band

Inside this band for (PV - SP), the control output does not change to protect the actuator (output Stand-by)

C.c. Control output cycle time**C.c. C** Cool cycle time

It's the cycle time of the SSR drive control output. The PID control output is provided by the pulse width modulation of the waveform.

OP. H Control output high limit**OP.C.H** Cool output high limit

It specifies the maximum value the control output can be set. It is applied in manual mode, too.

S.O.u.t Output Safety Value

Output Value in case of input anomaly

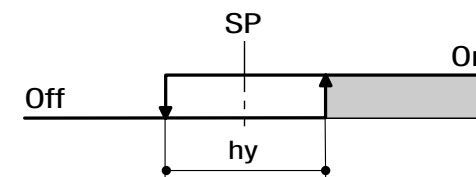
H.y. Control output hysteresis**H.y. C** Cool output hysteresis

Control or alarm output hysteresis span, set in % of the full scale.

4.4.2 CONTROL MENU

4.4.2.2 HEAT / COOL CONTROL

By a sole PID control algorithm, the controller handles two different outputs, one of these performs the Heat action, the other one the Cool action.

It is possible to overlap the outputs.

The dead band parameter \boxed{dbnd} , is the zone where it is possible to separate or overlap the Heat and Cool actions.

The Cool action can be adjusted using the relative cool gain parameter $\boxed{r.c.g.d}$.

To limit the Heat and Cool outputs the parameters $\boxed{OP.H}$ and $\boxed{OP.HC}$ can be used.

When there is an overlap, the displayed output \boxed{OUT} shows the algebraic sum of the Heat and Cool outputs.

A Heat /Cool actions separated

Insert positive \boxed{dbnd} value (0...10%)

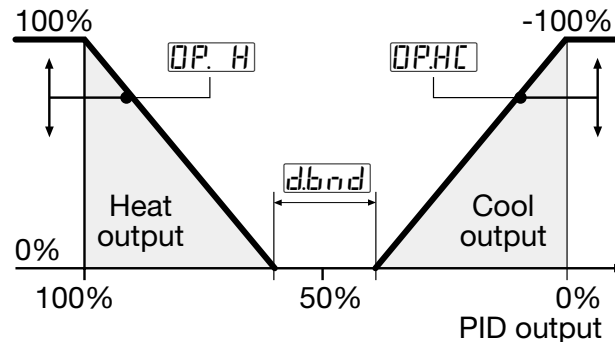

B Heat /Cool actions overlapped

Insert negative \boxed{dbnd} value (-10...0%)

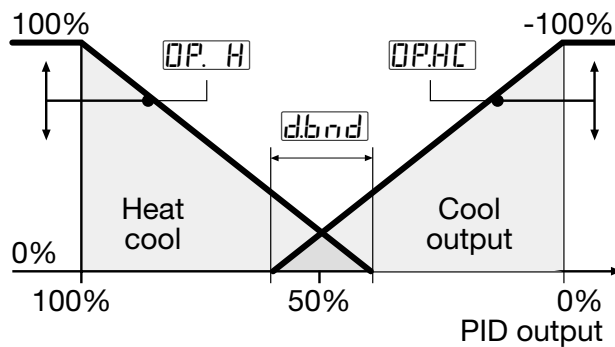

C Cool action adjusting

Example with different relative cool gains

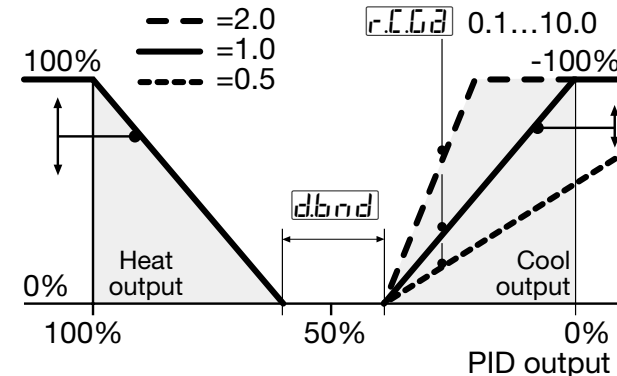

D On-Off Cool action

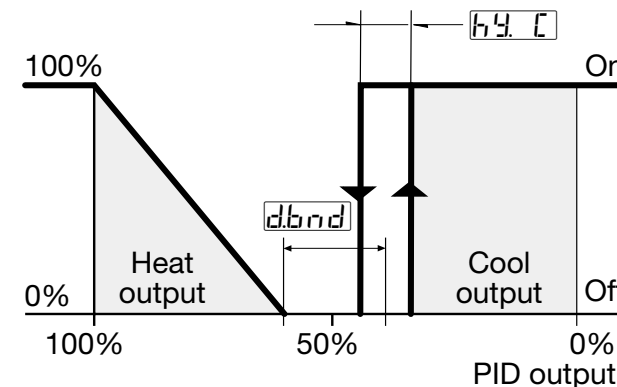

4.4.3 AUXILIARY PARAMETERS MENU

A 16.9 AL1
alarm hysteresis

A 26.9 AL2
alarm hysteresis

A 36.9 AL3
alarm hysteresis

Hysteresis of the threshold of both the alarms, that activate OP1 and OP2 control output. It is specified as a % of the full scale.

A 1L.b AL1, AL2, AL3
latching

A 2L.b and
blocking

A 3L.b functions

For each alarm it is possible to select the following functions

none none
Ltch latching
bl oc blocking
Lt.bl both latching
and blocking

Ltch ALARM

ACKNOWLEDGE FUNCTION

The alarm, once occurred, is presented on the display until to the time of acknowledge. The acknowledge operation consists in pressing any key.

After this operation, the alarm leaves the alarm state only when the alarm condition is no longer present.

bl oc START-UP DISABLING

Ramp down

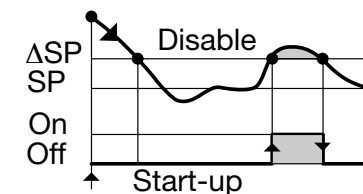

Ramp up

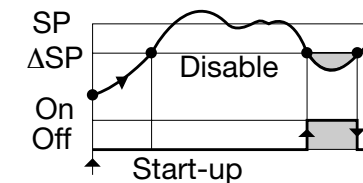

ΔSP Threshold = $SP \pm \text{range}$

4.4.3 AUXILIARY PARAMETERS MENU

ALARMS WITH LBA (LOOP BREAK ALARM)

AND SENSOR BREAK OPERATIONSELECT the code 1 on **O**, **P** or **Q** configuration indexes (see pages 21 or 22). The following parameter is then available:

L.L.b.d LBA delay

Setting a value between 1 and 9999 sec the alarm works as LBA+Sensor break with delay [1]

This condition is shown by means a red led as well as the blinking PV display.

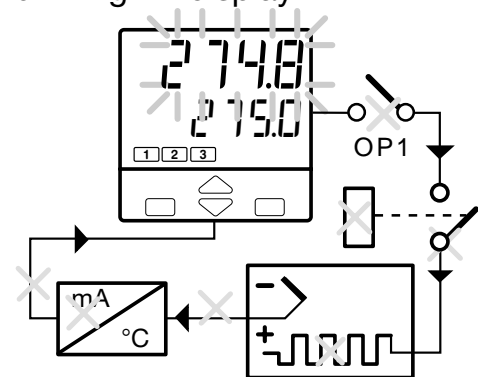

Setting OFF the alarm works as Sensor break with immediate action.

This condition is shown by means the red led of the selected alarm as well as:

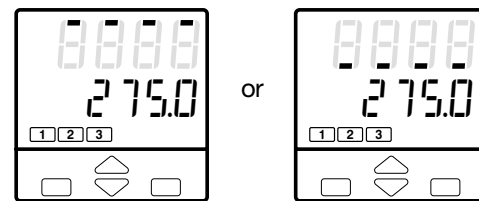

Note [1] In case of sensor break, condition, the alarm action is immediate.

When the cause of the alarm disappears, the alarm status stops.

S.E.O.P Soft-start control output value

Value of the control output during the Soft-start activation time.

S.E.E.T Soft-start activation time

Time duration (starting from the power on) of the Soft-start function.

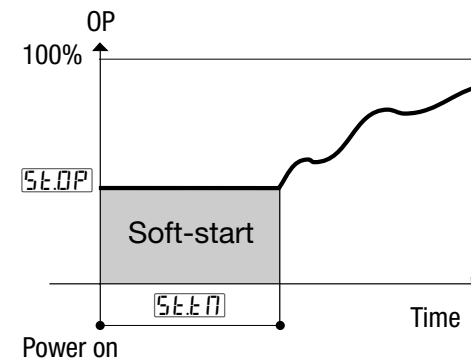

t.F.i.l Input filter time constant

Time constant, in seconds, of the RC input filter applied to the PV input.

When this parameter is set to **OFF** the filter is bypassed.

Filter response

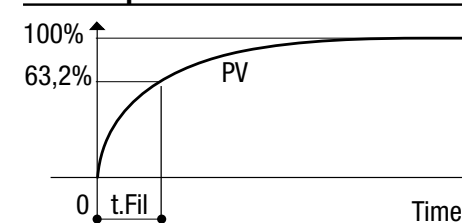

1n.5h Input shift

This value is added to the measured PV input value. Its effect is to shift the whole PV scale of up to ± 60 digits.

Addr**Controller address**

the address range is from 1 to 247 and must be unique for each controller on the communication bus to the supervisor.

When set to **OFF** the controller is not communicating

rt.Lo**Retransmission low range****rt.Hi****Retransmission high range****4.4.4 TIMER AND START-UP MENU (OPTION)**

To improve the instrument performances and to reduce the wiring and installation costs, two special functions are available:

4.4.4.1 Start-up**4.4.4.2 Timer**

In order to have the above functions the product code digit **E** must be **2** (see page 19)

For example: X3 3100-2000

To select these functions use the parameter: (see page 41).

t.Nod**Timer/Start-up operator mode**

⚠ Selecting Timer or Start-up, the Soft-start function is disabled, therefore the parameters **SE.OP and **SE.EN** will not be shown.** (see page 29)

4.4.4.1 START-UP FUNCTION (OPTION)

By means of this function it is possible to manipulate the control output when the controller is switched on.

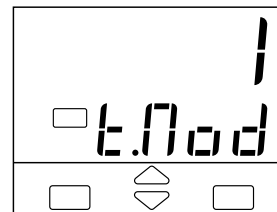

To configure Start-up function the parameter

“Timer/Start-up operating mode” must be set to **1** (see page 41)

Three parameters are associated to the Start-up function.

t.h.s.u**Start-up hold time**

0...500 min.

s.p.s.u**Start-up Setpoint**

(S.P. L ... S.P. H)

OP.HS**Control output high limit**

5.0%...100.0%

The Start-up function includes three phases:

1st “Limy” - The control output is limited to the **OP.HS**

2nd “Hold” - The process variable is maintained to the Start-up Setpoint for the time fixed by the parameter **t.h.s.u**

3rd “Off” - When the **t.h.s.u** time is elapsed the process variable is maintained to the working Setpoint.

Whether the process variable, for any reason (e.g. load change), decreases at a value lower than (**s.p.s.u** - 40 digits), the Start-up function starts again from the “Limy” phase.

4.4.4.1 START-UP FUNCTION (OPTION)

When the Start-up is in Hold phase, if the local Setpoint becomes lower than the Start-up Setpoint or if the operating mode changes to manual, the Start-up function passes to the “Off” phase.

There are two possibilities:

A Start-up Setpoint SP_{SU} lower than the local Setpoint.

The “Hold” phase starts when the process variable PV achieves the SP_{SU} (with a tolerance of 1 digit).

B Start-up Setpoint SP_{SU} greater than or equal to the local Setpoint.

When the process variable PV achieves the local Setpoint (with a tolerance of 1 digit), the Start-up function passes directly to the “Off” phase.

If, at the controller power-on, the process variable PV is greater than the lowest between the SP_{SU} and the working Setpoint, the next phase (“Hold” or “Off”) will be executed instead of the “Limy” phase.

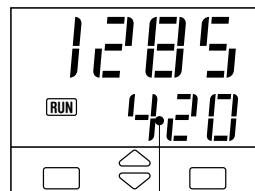

Start-up Setpoint

During the “Limy” and “Hold” phases the **RUN** led is on.

A $SP_{SU} < \text{local Setpoint SP}$

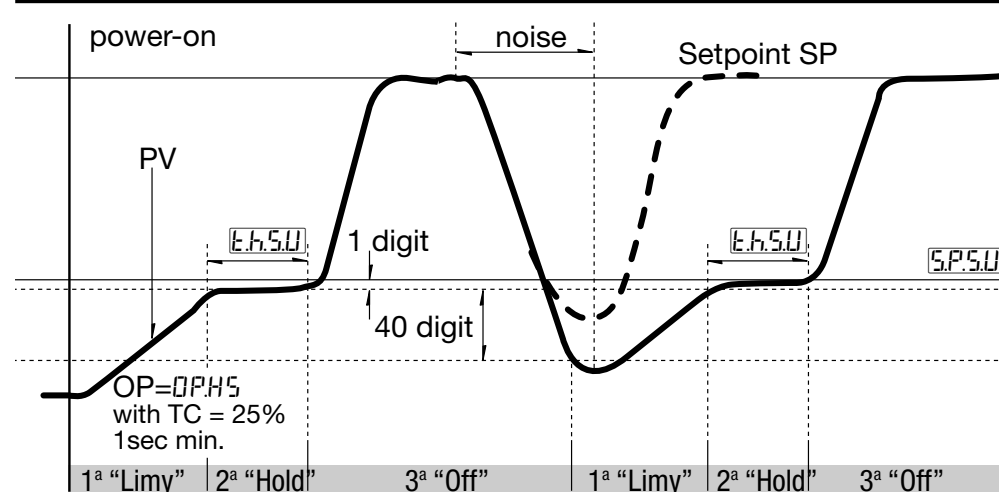

B $SP_{SU} \geq \text{Setpoint locale SP}$

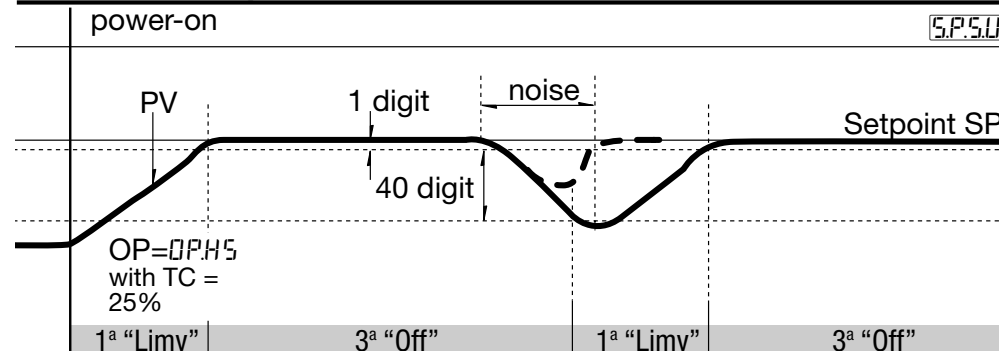

4.4.4.2 TIMER FUNCTION (OPTION)

⚠ The Timer can't be enabled with Heat / Cool control.

To enable this function do the following:

- 1 In order to use this AL3 function, index **Q** must be set to in configuration (see p. 20).
- 2 To select one of the 6 possible functioning modes of the Timer, set the value of the 2 following parameters in parameterisation (see p. 27).

t.Mod Timer/Start-up operating mode

By this parameter can be defined: (see table 1)

- the counting start time
- the control output status at the end of the counting

table 1

Timer/Start-up counting mode		Value
Disabled		0FF
Start-up function		1
Counting start time	End mode	
When inside the band	Control mode	2
	Output to 0	3
When launched	Control mode	4
	Output to 0	5
When launched. Control disabled	Control mod	6
When launched stand-by Setpoint	Control mod	7

Now the other parameter values can be entered:

t.Action Timer Action

By this parameter can be defined:(see table 2)

- the time units
- the starting mode
- the OP3 status when the timer is running.

When the timer is not running, the OP3 takes the opposite status.

table 2

Time units	Starting mode	[1] OP3 status	Value
Seconds	Manual by keypad	Off	0
		On	1
	Aut at the power on [2]	Off	2
		On	3
Minutes	Manual by keypad	Off	4
		On	5
	Aut at the power on [2]	Off	6
		On	7

[1] If used by Timer

[2] Using this selection, manual starting mode is possible too.

t.time Timer setting

(1...9999 sec/min.)

S.P.Sb Stand-by Setpoint

(only for t.Mod = 7)
(S.P. L...S.P. H)

4.4.4.2 TIMER FUNCTION (OPTION)

TIMER COUNTING MODES

A - Counting start time inside the band, end in control mode.

The time counting starts only when the error is inside a ± 1 digit band. The control action is not affected by the Timer function.

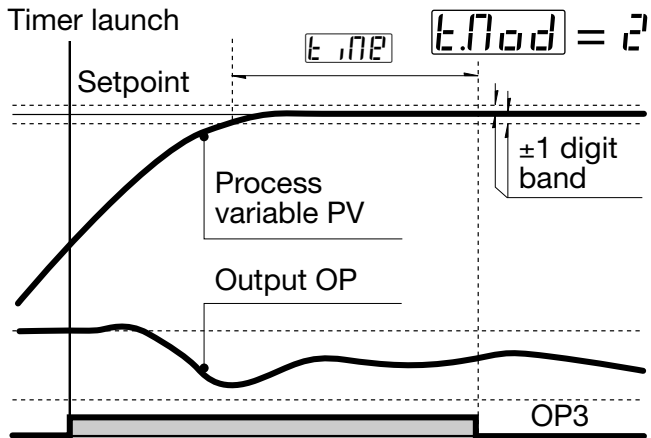
**B - Counting start time inside the band, end with control output forced to zero.**

The time counting starts only when the error is inside a ± 1 digit band. At the end, the control output is forced to zero. [1]

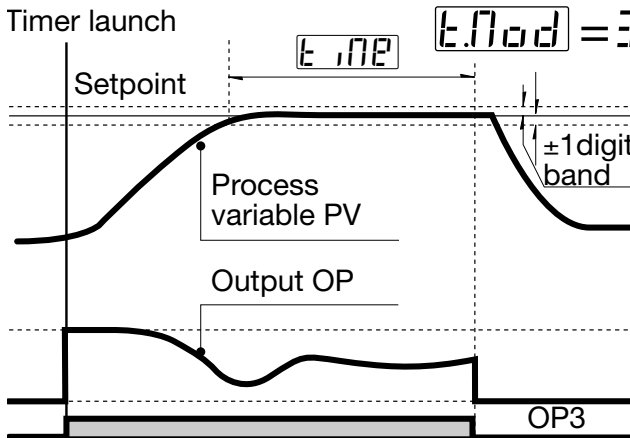
**C - Counting start time = timer launch time, end in control mode.**

The time counting starts when the timer is launched. The control action is not affected by the Timer function.

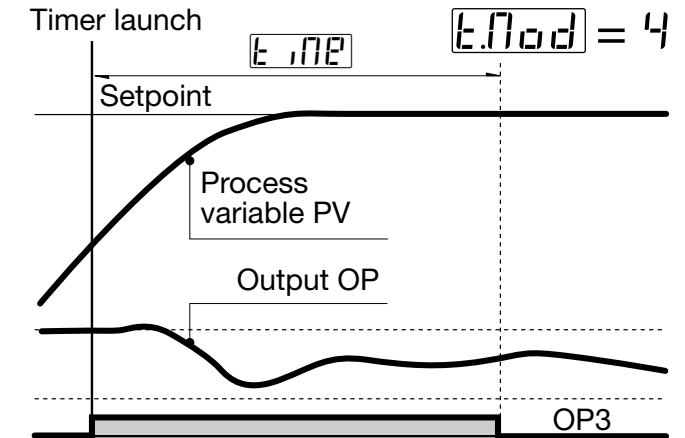

[1] When the Timer is not running the control output is forced to zero, also before the Timer launch

TIMER COUNTING MODES

D - Counting start time = timer launch time, end with control output forced to zero.

The time counting starts when the timer is launched. At the end, the control output is forced to zero. [1]

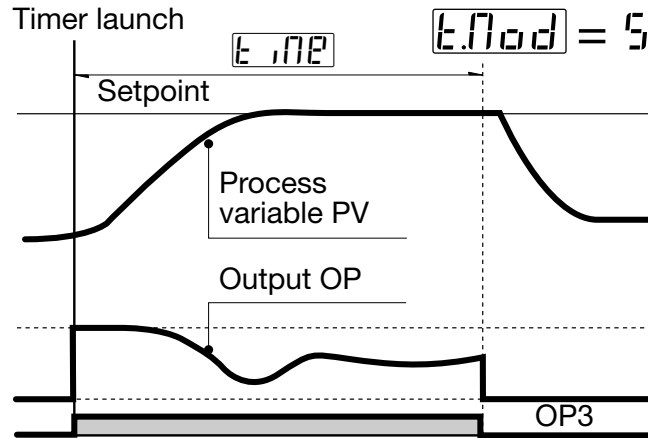

[1] When the Timer is not running the control output is forced to zero, also before the Timer launch

E - No control action during the counting time.

The time counting starts when the timer is launched and the control output is forced to zero. At the end, the control action starts.

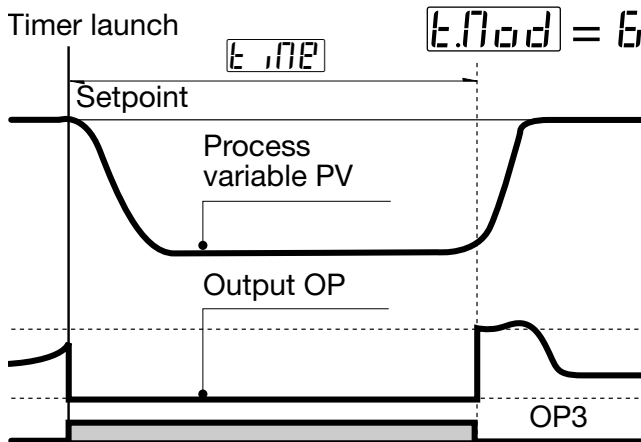

F - Control action with stand-by Setpoint during the counting time

The time counting starts when the timer is launched and the control action use the Stand-by Setpoint. At the end, the control action use the working Setpoint.

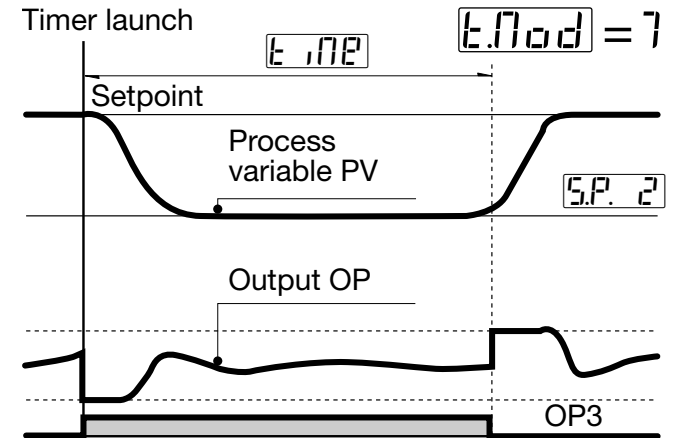

4.4.4.2 TIMER FUNCTION (OPTION)

POWER FAILURE

If there is a power failure during the Timer execution, the value of the elapsed time is lost.

Depending on Timer action `t.act` selection, when the controller restarts you can have two different situations:

- with automatic mode (`t.act` = 2, 3, 6, 7), the Timer function starts again and the counting time is reinitialised.
- with manual mode (`t.act` = 0, 1, 4, 5), the control output is forced to 0 if `t.mod` = 3 e 5; otherwise the control action restarts using the working Setpoint

TIMER STARTING

See the Timer starting procedure at page 49

DISPLAY

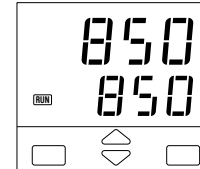

When the Timer is running, the led `RUN` is on.

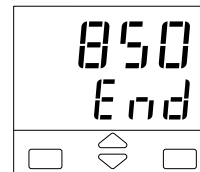

When the Timer ends, the Setpoint display shows alternatively the message `End` and the Setpoint value until a key is pressed.

TIMER REMAINING TIME

When the timer is running it is always possible to see the remaining time and to modify it.

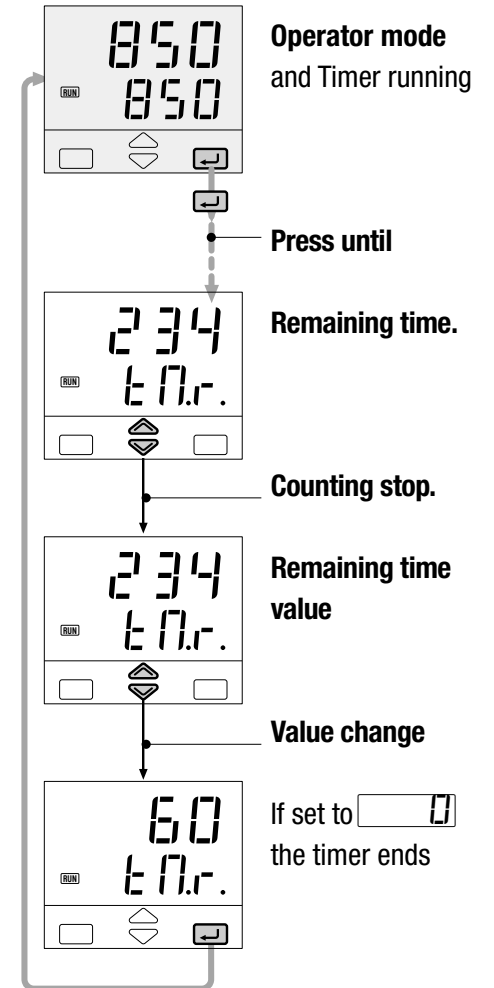

4.4.5 CONFIGURATION MENU

RETRANSMISSION

When OP5 output is present and not configured as control output, it retransmits linearised PV or SP.

On configuration (see page 29) it is possible to set

rt.r **Output range**
0-20 / 4-20

rt.H **Retransmitted signal**
nonP P.U. / S.P.

The following parameters define the low and high range of the OP5 retransmission output corresponding to 0...4mA or 20mA (see page 27):

rt.Lo **Retransmission low range**

rt.Hi **Retransmission high range**

Example:

- T/C S, range 0...1600°C
- Output range, 4...20 mA
- Retransmitted signal PV on 800...1200°C range

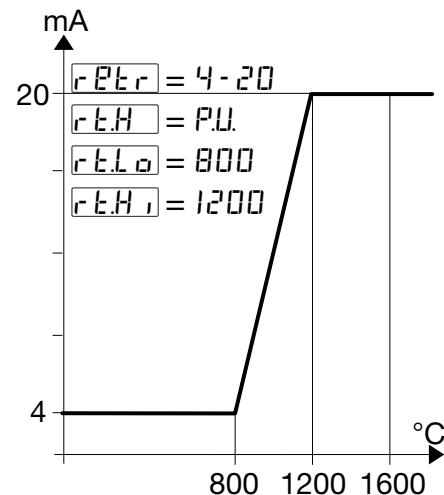

With $rt.Lo$ greater than $rt.Hi$, it is possible to obtain a reverse scale.

CURRENT TRANSFORMER INPUT

With CT option, it is possible to display the load current and set an alarm threshold.

The setting can be done by means the 8 or 9 configuration index of the codes O, P or Q (see pages 19 and 20).

It is possible to set one of the alarms (see pages 19 and 20) to have an alarm when, during the ON time of the time proportional output, the load current is less than the specified threshold (index 8), or during the OFF time there is a value > 3% of full scale load current.

The alarm condition must be longer than 120 ms to set the alarm.

By the parameter **ALF.5** **CT primary high range**
OFF / 1...200A

the load current display can be adapted to the transformer characteristics. (OFF means disabled)

During the OFF time the parameter **ELUR** latches the last on time current value

4.4.5 CONFIGURATION MENU

CURRENT TRANSFORMER INPUT

Example:

CT input on OP1, alarm on AL2 during on time (configuration digit

0 = 8, , see page 19)

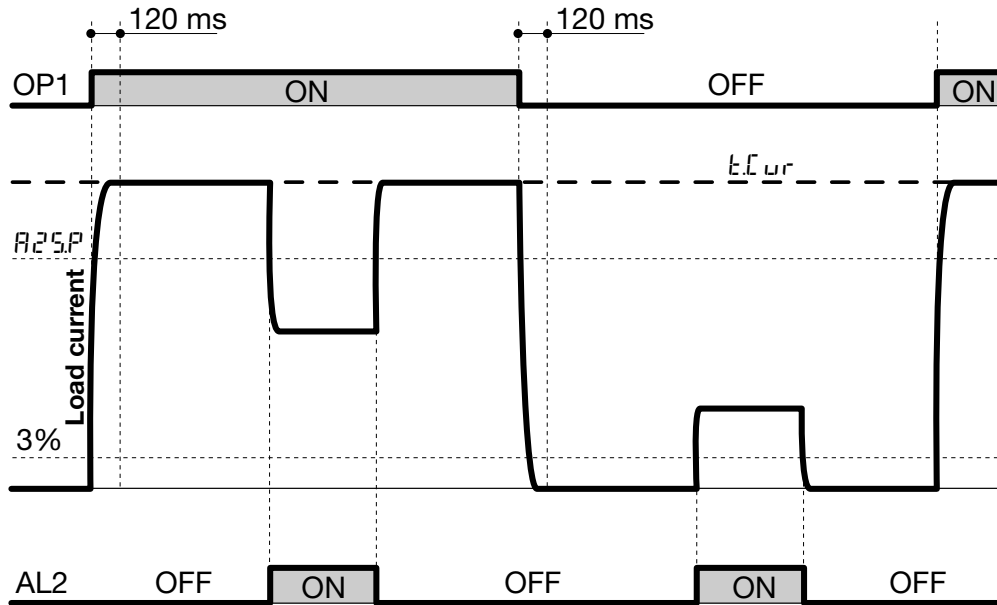

SERIAL COMMUNICATIONS

Prot Communication protocol
Modbus/ Dbus

baud Baud rate
 1200/2400
 4800/9600

5 DISPLAYS

5.1 OF THE PROCESS VARIABLES

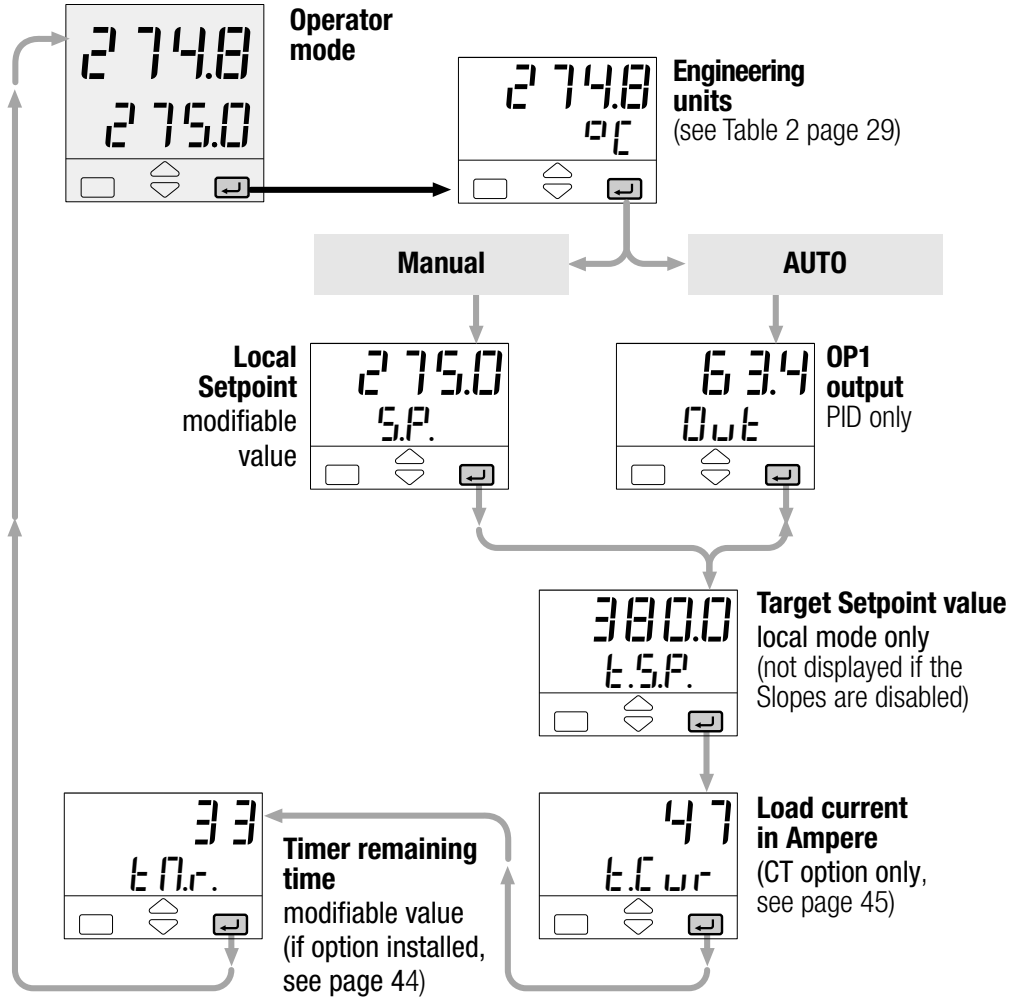

5.2 OF THE CONFIGURATION CODES

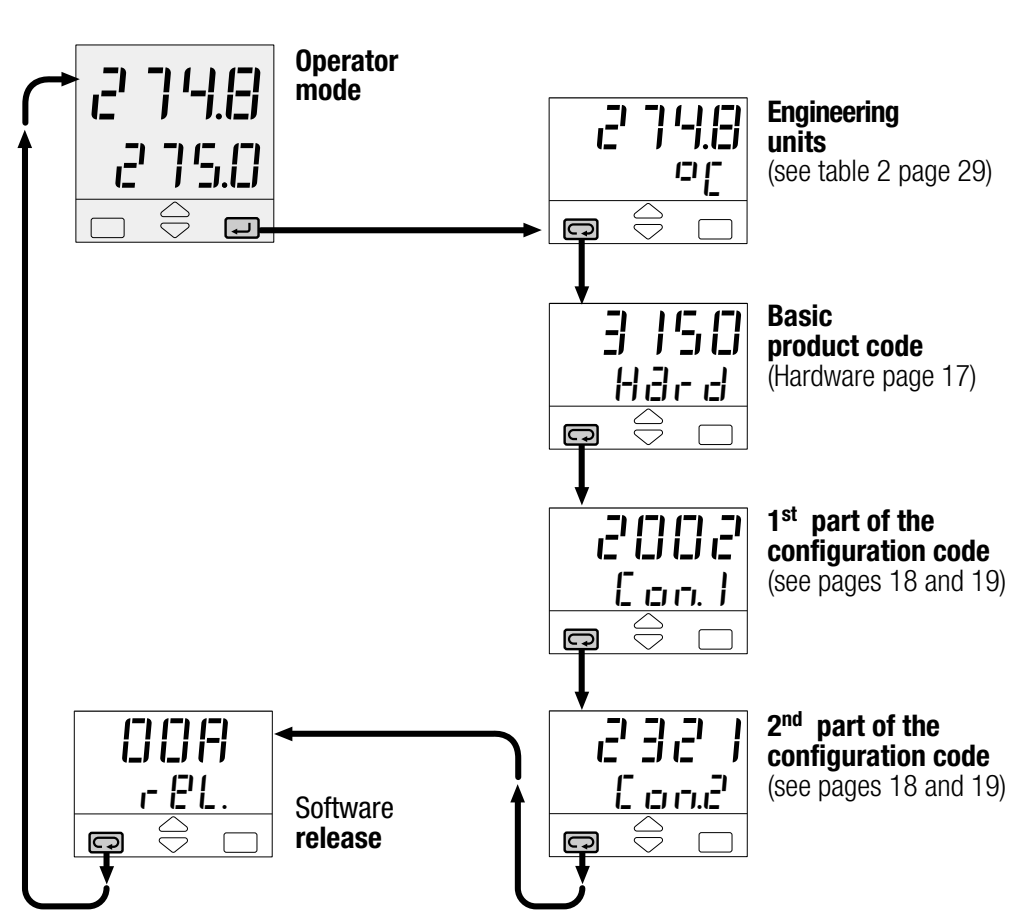

6 COMMANDS

COMMANDS TO THE CONTROLLER AND OPERATING PHASES

The commands can be entered in 2 ways:



6.1 KEYPAD

see page 49

- Setpoint modification
- Timer start
- Local/remote selection
- Stored Setpoint display
- Keypad lock
- Outputs lock





6.2 SERIAL COMMUNICATIONS

see the manual on this topic

6.1 KEYPAD COMMANDS

6.1.1 SETPOINT MODIFICATION

The Setpoint is directly modified with the   keys. Once entered, the new value is checked and becomes operating after 2 seconds.. The end of this phase is flagged by flashing momentarily the display with SP.

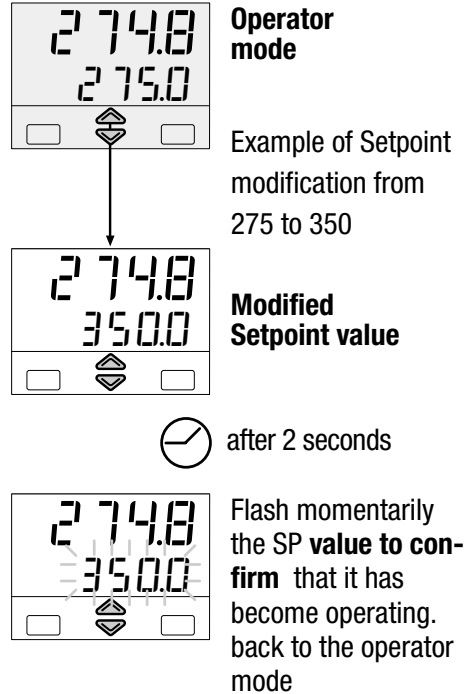

6.1.2 TIMER STARTING (option)

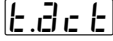
Depending on the Timer action  selection, there can be two different starting ways:

- Automatic at the power on
- Manual by keypad, digital inputs or serial communications.

To start/stop the Timer:

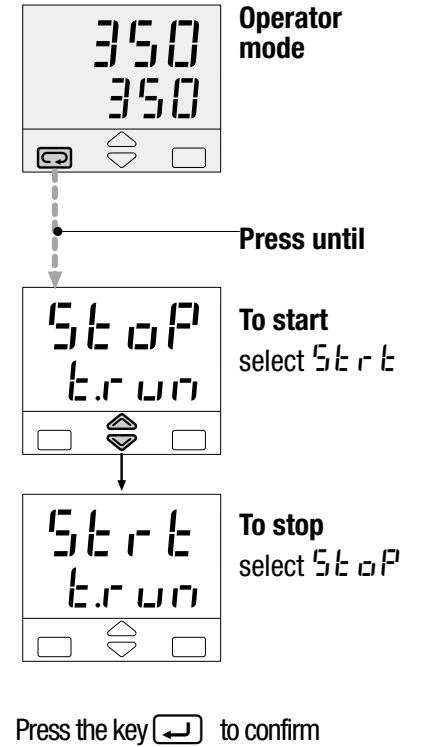

6.1 KEYPAD COMMANDS

6.1.3 LOC/ REM SELECTION

configuration index **R** = 4 or 5)

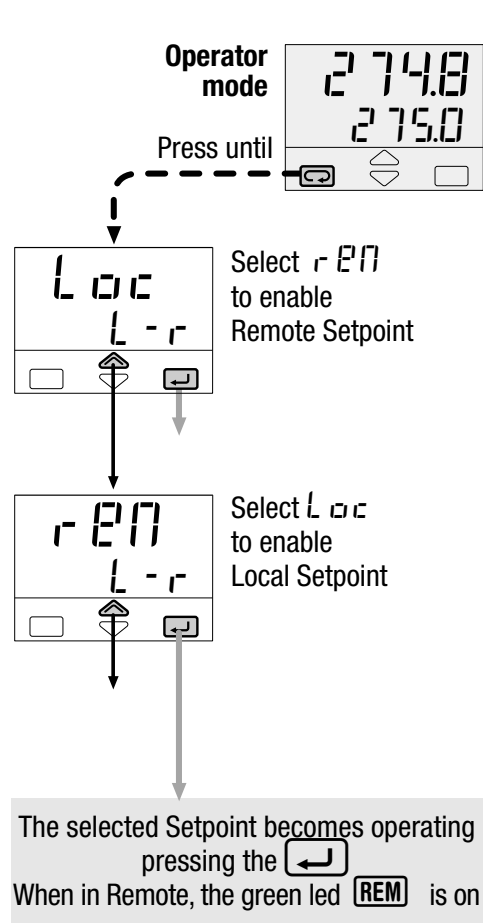

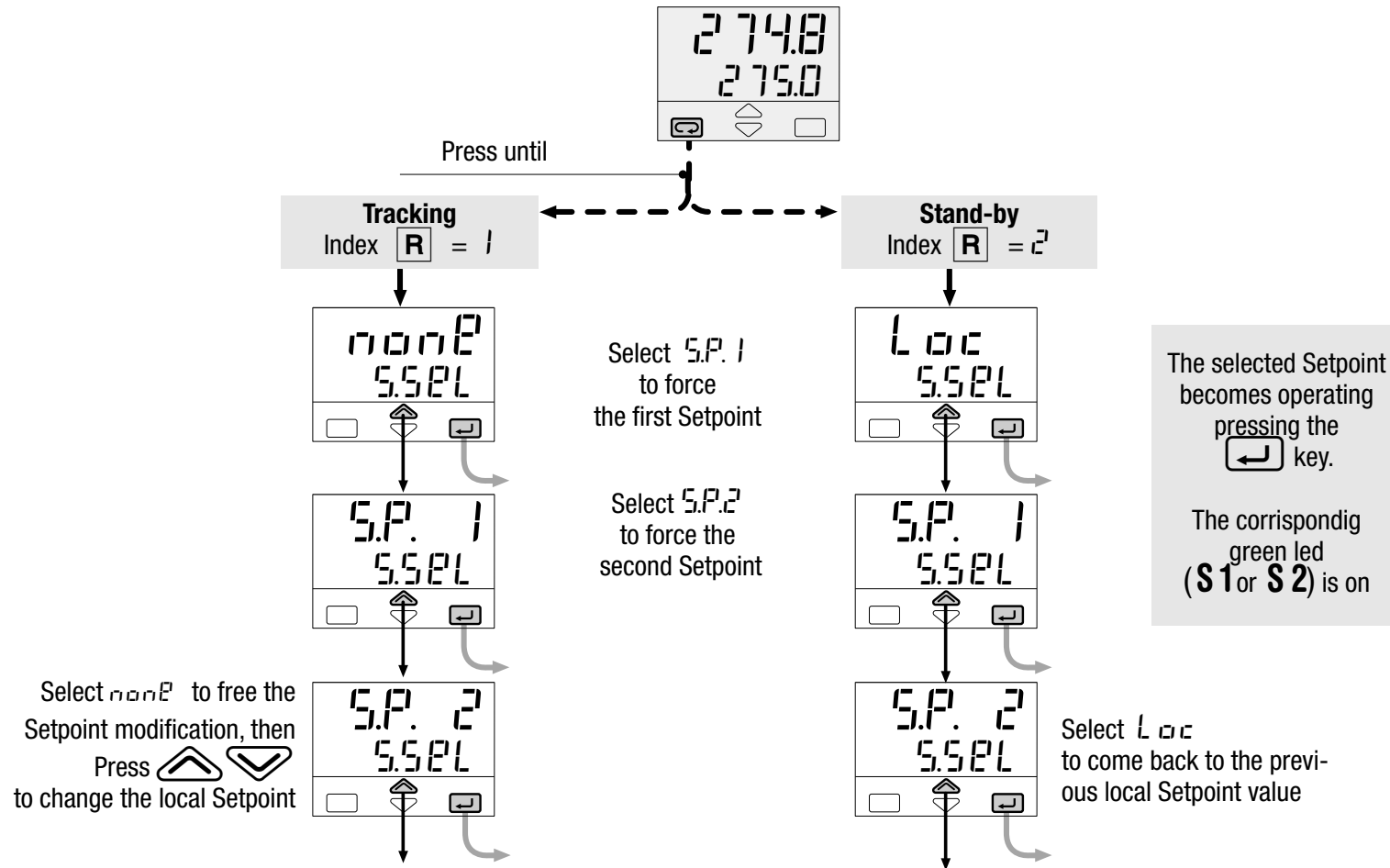

6.1.4 STORED SETPOINTS SELECTION

(configuration index **R** = 1 or 2)



6.1.5 KEYPAD LOCK

To lock/unlock the keypad press the keys  and  simultaneously for 2 seconds.



To confirm the keypad lock/unlock the display flashes once.

The keypad lock/unlock can be achieved by serial communications too.

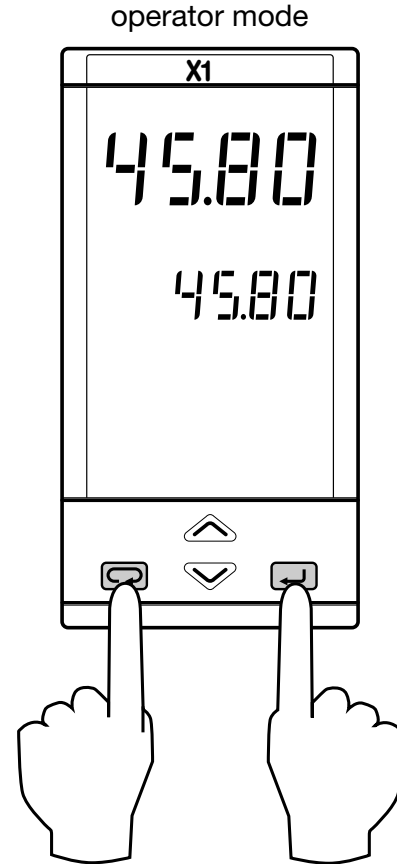
 The keypad lock is maintained in case of power failure.



6.1.6 OUTPUTS LOCK

The outputs are switched to the OFF status by pressing the keys  and  together.

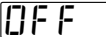
When the outputs are locked, the message  is displayed instead of the Setpoint value.

To unlock the outputs press again the keys simultaneously (the Soft-start will be enabled).

The outputs lock/unlock can be achieved by serial communications too

 The outputs lock/unlock is maintained in case of power failure.

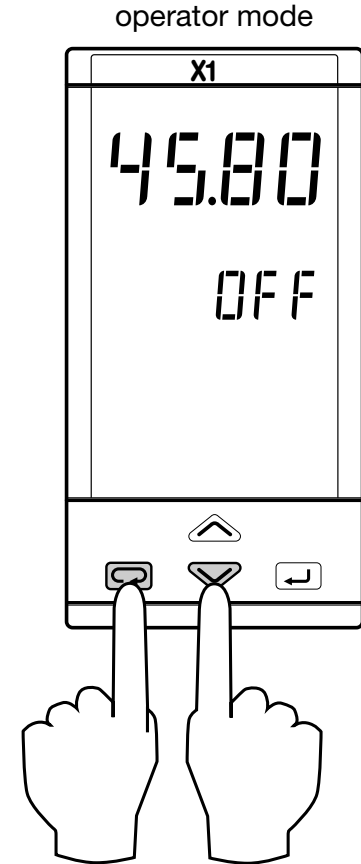

7 TECHNICAL SPECIFICATIONS

Features (at 25°C environmental temp.)	Description			
Total configurability (see chapter 3.2 page 18 chapter 4.3.5 page 28)	From keypad or serial communication the user selects: <ul style="list-style-type: none"> - the type of input - the type of control algorithm - the type of output - the type and functionality of the alarms - the type of Setpoint - control parameter values 			
PV Input (see pages 11,12 and page 18)	Common characteristics		A/D converter with resolution of 50.000 points Update measurement time: 0.2 seconds Sampling time: 0.5 seconds Input bias: - 60...+ 60 digit Input filter with enable/disable: 1...30 seconds	
	Accuracy		0.25% ± 1 digits for temperature sensors 0.1% ± 1 digits (for mV and mA)	
	Resistance thermometer (for ΔT: R1+R2 must be <320Ω)	Pt100Ω at 0°C (IEC 751) °C/°F selectable	2 or 3 wires connection Burnout (with any combination)	Between 100...240V~ the error is minimal Max. wire Res: 20Ω max (3 wires) Sensitivity: 0.1°C/10° E. T. <0.1°C / 10Ω Wire Res.
	Thermocouple	L, J, T, K, S, R, B, N, E, W3, W5 (IEC 584) R _j >10MΩ °C/°F selectable	Internal cold junction compensation con NTC Error 1°C/20°C ±0.5°C Burnout	Line: 150Ω max Input drift: <2μV/°C.Env. Temp <0.5μV / 10Ω Wire Res.
	DC input (current)	4...20mA, 0-20mA with external shunt 2.5Ω R _j >10MΩ	Burnout. Engineering units Conf. decimal point position Init. Scale -999...9999	Input drift: <0.1% / 20°C Env. Temp. <0.5μV / 10Ω Wire Res.
	DC input (voltage)	10...50mV, 0-50mV R _j >10MΩ	Full Scale -999...9999 (min. range of 100 digits)	

Features (at 25°C environmental temp.)		Description						
Auxiliary inputs	Remote Setpoint (option) Not isolated accuracy 0.1%	Current 0/4...20mA Rj = 30Ω	Bias in engineering units and ± range Ratio from -9.99...+99.99 Local + Remote Setpoint					
		Voltage 1-5/ 0-5/ 0-10V Rj = 300KΩ						
	CT current transformer (see pages 12 and 45)	50 or 100 mA input hardware selectable	Current visualisation 1...200A With 1A resolution and Heater Break Alarm					
Operating mode and Outputs	1 single or double action PID loop or On/Off with 1, 2 or 3 alarms	Single action	Control output		AL1 alarm	AL2 alarm	AL3 alarm	Retransmiss.
			OP1 -Relay/Triac			OP2 -Relay/Triac	OP3 -Relay	OP5 -Analogue
		OP4 -SSR drive		OP1 -Relay/Triac	OP2 -Relay/Triac	OP3 -Relay	OP5 -Analogue	
		Double action Heat / Cool	OP1 -Relay/Triac	OP2 -Relay/Triac			OP3 -Relay	OP5 -Analogue
			OP1 -Relay/Triac	OP4 -SSR drive		OP2 -Relay/Triac	OP3 -Relay	OP5 -Analogue
			OP4 -SSR drive	OP2 -Relay/Triac	OP1 -Relay/Triac		OP3 -Relay	OP5 -Analogue

7 - Technical specifications

Features (at 25°C environmental temp.)	Description				
Control mode	Algorithm	PID with overshoot control or On-off - PID with valve drive algorithm, for controlling motorised positioners			
	Proportional band (P)	0.5...999.9%			
	Integral time (I)	0.1...100.0 min	OFF = 0		
	Derivative time (D)	0.01...10.00 min			
	Error dead band	0.1...10.0 digit			
	Overshoot control	0.01...1.00		Single action PID algorithm	
	Manual reset	0.0...100.0%			
	Cycle time (Time proportional only)	1...200 sec			
	Control output high limit	10.0...100.0%			
	Soft-start output value	0.1...100.0%	OFF = 0		
	Output safety value	0.0...100.0% (-100.0...100.0% for Heat / Cool)			
	Control output hysteresis	0.1...10.0%		On-Off algorithm	
	Dead band	-10.0...10.0%			
	Relative cool gain	0.1...10.0			
	Cycle time (Time proportional only)	1...200 sec		Double action PID algorithm (Heat / Cool) with overlap	
	Control output high limit	10.0...100.0%			
	Cool output hysteresis	0.1...10.0%			

Features (at 25°C environmental temp.)	Description			
OP1-OP2 outputs	SPST Relay N.O., 2A/250V~ for resistive load Triac, 1A/250V~ for resistive load			
OP3 output	SPDT relay N.O., 2A/250V~ for resistive load			
OP4 output	SPDT relay N.O., 2A/250V~ for resistive load			
OP5 analogue output (option)	Control or PV/SP retransmission	Galvanic isolation: 500 V~/1 min Resolution 12bit (0.025%) Accuracy: 0.1 %	In current: 0/4...20mA, 750Ω / 15V max	
AL1 - AL2 - AL3 alarms	Hysteresis 0.1...10.0% c.s.			
	Action	Active high	Action type	
		Active low		Deviation threshold ±range
		Special functions	Band threshold 0...range	
	Absolute threshold whole range			
Sensor break, heater break alarm				
Setpoint	Local			
	Local			
	Local and Remote	If option installed	Up and down ramps 0.1...999.9 digit/min. (OFF=0) Low limit: from low range to high limit High limit: from low limit to high range	
	Local with trim			
	Remote with trim			

Features (at 25°C environmental temp.)	Description		
Special functions (option)	Timer (see page 41)	Automatic start at the power on, manual start by keypad, Digital inputs or serial comm.s	
		Tempo di esecuzione: 1...9999 sec/min	
	Start-up (see page 39)	Stand-by Setpoint: from Setpoint low limit to Setpoint high limit	
		Start-up Setpoint: from Setpoint low limit to Setpoint high limit	
		Hold time: 0...500min	
Control output high limit: 5.0...100.0%			
Fuzzy-Tuning one shoot	The controller selects automatically the best method according to the process conditions	Step response	
Serial comm. (option)		Natural frequency	
Auxiliary Supply	RS485 isolated, Modbus/Jbus protocol, 1200, 2400, 4800, 9600 bit/sec, 3 wires		
Operation alarm safety	+24V– ± 20% 30mA max - for external transmitter supply		
	Measure input	Detection of out of range, short circuit or sensor break with automatic activation of the safety strategies and alerts on display	
	Control output	Safety value: -100%...100%	
	Parameters	Parameter and configuration data are stored in a non volatile memory for an unlimited time	
General characteristics	Access protection	Password to access the configuration and parameters data, keypad lock, outputs lock	
General characteristics	Power supply (fuse protected)	100 - 240V~ (-15% + 10%) 50/60Hz or 24V~ (-15% + 25%) 50/60Hz e 24V– (-15% + 25%)	Power consumption 4W max
	Safety	Compliance to EN61010-1 (IEC 1010 – 1), installation class 2 (2500V) pollution class 2, instrument class II	
	Electromagnetic compatibility	Compliance to the CE standards (see page 2)	
	Protection EN60529 (IEC529)	IP65 front panel	
	Dimensions	1/8 DIN - 48 x 96, depth 110 mm, weight 250 gr. apx.	



WARRANTY

We warrant that the products will be free from defects in material and workmanship for 3 years from the date of delivery.

The warranty above shall not apply for any failure caused by the use of the product not in line with the instructions reported on this manual.

ASCON'S WORLDWIDE SALES NETWORK

SUBSIDIARY

FRANCE

ASCON FRANCE

Phone 0033 1 64 30 62 62

Fax 0033 1 64 30 84 98

AGENCE SUD-EST

Phone 0033 4 74 27 82 81

Fax 0033 4 74 27 81 71

DISTRIBUTORS

ARGENTINA

MEDITECNA S.R.L.

Phone +5411 4585 7005

Fax +5411 4585 3434

AUSTRALIA

IPA INDUSTRIAL PYROMETER

(Aust) PTY.LTD

Phone +61 8 8352 3688

Fax +61 8 8352 2873

FINLAND & ESTONIA

TIM-TOOL OY

Phone +358 50 501 2000

Fax +358 9 50 55 144

GERMANY

MESA INDUSTRIE ELEKTRONIK GMBH

Phone +49 2365 915 220

Fax +49 2365 915 225

GREECE

CONTROL SYSTEM

Phone +30 31 521 055-6

Fax +30 31 515 495

BRANCH OFFICE

Phone +30 1 646 6276

Fax +30 1 646 6862

HOLLAND

HSD INSTRUMENTS

Phone +31 78 617 03 55

Fax +31 78 618 26 68

PORTUGAL

REGUIPAMENTOS LDA

Phone +351 21 989 0738

Fax +351 21 989 0739

SPAIN

INTERBIL S.L.

Phone +34 94 453 50 78

Fax +34 94 453 51 45

BRANCH OFFICE

Phone +34 93 311 98 11

Fax +34 93 311 93 65

Phone +34 91 656 04 71

Fax +34 91 677 21 26

SWITZERLAND

CONTROLTHERM GMBH

Phone +41 1 954 37 77

Fax +41 1 954 37 78

TURKEY

KONTROL SISTEMLERI LTD

Phone +90 216 302 19 70-71

Fax +90 216 302 19 72

UNITED KINGDOM

EUKERO CONTROLS LTD

Phone +44 20 8568 4664

Fax +44 20 8568 4115